



Powerchief® POW'R Products
Generator

Series PC

Installation & Operating Manual

WARNING:

CALIFORNIA PROPOSITION 65 WARNING:

Engine exhaust from this product contains chemicals known to the state of California to cause cancer, birth defects and other reproductive harm.

WARNING:

CALIFORNIA PROPOSITION 65 WARNING:

Battery posts, terminals and related accessories are known to the state of California to cause cancer, birth defects and other reproductive harm.

Table of Contents

Section 1	
Product Safety Information	1-1
Safety Notice	1-1
Responsibility	1-1
IMPORTANT SAFETY INSTRUCTIONS	1-2
Caution Statements	1-6
Section 2	
General Information	2-1
Limited Warranty	2-1
Owner's Responsibilities	2-2
Limitations	2-2
Section 3	
Receiving & Installation	3-1
Receiving & Inspection	3-1
Lifting the Generator	3-1
Storage	3-1
Physical Location	3-2
Installation	3-2
Electrical Connections	3-2
Frame Ground Connection	3-3
Engine Oil	3-4
Battery Connections	3-4
Use of Electric Motor Loads	3-5
Optional Wheel Kit	3-6
Recommended Engine Oil and Battery Type	3-6
Section 4	
Operation	4-1
Operator Control Panel	4-1
Pre-Start Checks	4-2
Start-Up Procedure	4-2
Electric Start	4-2
Recoil Start	4-2
Stopping Procedure	4-2
Section 5	
Troubleshooting and Maintenance	5-1
Maintenance	5-1
Problems and Solutions	5-2
Appendix A	
Powerchief® Series	A-1
Operator Panel Configuration	A-1
Replacement Parts	A-2
Wiring Diagrams	A-3
Appendix B	
Special Information for California	B-1

Section 1

Product Safety Information

Safety Notice

Be sure that you are completely familiar with the safe operation of this equipment. This equipment may be connected to other machines that have rotating parts or parts that are controlled by this equipment. Improper use can cause serious or fatal injury. Always disconnect all electrical loads before starting the generator.

Installation and repair procedures require specialized skills with electrical generating equipment and liquid cooled engine systems. Any person that installs or repairs this generator must have these specialized skills to ensure that this generating unit is safe to operate. Contact Baldor service department for repairs or any questions you may have about the safe installation and operation of this system.

The precaution statements are general guidelines for the safe use and operation of this generator. It is not practical to list all unsafe conditions. Therefore, if you use a procedure that is not recommended in this manual you must determine if it is safe for the operator and all personnel in the proximity to the generator and connected loads. If there is any question of the safety of a procedure please contact Baldor before starting the generator.

This equipment contains high voltages. Electrical shock can cause serious or fatal injury. Only qualified personnel should attempt the start-up procedure or troubleshoot this equipment.

This equipment may be connected to other machines that have rotating parts or parts that are driven by this equipment. Improper use can cause serious or fatal injury. Only qualified personnel should attempt the start-up procedure or troubleshoot this equipment.

- System documentation must be available to anyone that operates this equipment at all times.
- Keep non-qualified personnel at a safe distance from this equipment.
- Only qualified personnel familiar with the safe installation, operation and maintenance of this device should attempt start-up or operating procedures.
- Always stop engine before making or removing any connections.
- Always stop engine and allow it to cool before refueling.

Responsibility

When your generator is delivered, it becomes the responsibility of the owner/operator of the generator set to prevent unsafe conditions and operation of the equipment. Some responsibilities include (but are not limited to) the following:

1. It is the responsibility of the owner/operator of this generator to ensure that this equipment is correctly and safely installed.
2. It is the responsibility of the owner/operator of this generator to ensure that this equipment, when installed fully complies with all federal, state and local codes.
3. It is the responsibility of the owner/operator of this generator to ensure that any person operating this equipment has been properly trained.
4. It is the responsibility of the owner/operator of this generator to ensure that any person operating this equipment has access to all manuals and information required for the safe use and operation of this equipment.
5. It is the responsibility of the owner/operator of this generator to ensure that it is properly maintained and safety inspected at regular scheduled intervals.
6. It is the responsibility of the owner/operator of this generator to ensure that any person who has not been trained on the safe use of this equipment does not have access to this equipment.

Read This Manual Thoroughly

If you do not understand any concept, any procedure, any safety warning statement, any safety caution statement or any portion of this manual, contact Baldor or your nearest authorized Baldor representative. We are happy to make sure you understand the information in this manual so that you can safely enjoy the full use of this generator.

Precaution Statements Used In This Manual

There are three classifications of precautionary statements used in this manual. The most critical is a **WARNING** statement, then the **Caution** statement and the least critical is the Note statement. The usage of each statement is as follows:

- WARNING:** Indicates a potentially hazardous situation which, if not avoided, could result in injury or death.
- Caution:** Indicates a potentially hazardous situation which, if not avoided, could result in damage to property.
- Note:** Additional information that is not critical to the installation or operation.

IMPORTANT SAFETY INSTRUCTIONS

SAVE THESE INSTRUCTIONS – This manual contains important instructions for the generator that should be followed during installation, operation and maintenance of the generator.

For ease of reading, the Warning statements are divided into four categories: Operation, Burn, Installation, and Maintenance.

Operation

- WARNING:** Gasoline and diesel fuel are flammable and can cause fire, explosions, injury or death. For storage or refueling handle fuel with care and only in clean, approved, properly marked safety fuel containers.
- WARNING:** Do not overfill the fuel tank. Only fill the tank to within 1/2" of the top of the tank to allow space for fuel expansion. Overfilling of tank may cause fuel to spill out onto engine and cause fire or explosion.
- WARNING:** Clean up fuel spills by wiping completely dry before starting engine. Gasoline and diesel fuel are flammable and can cause fire, explosions, injury or death.
- WARNING:** Make sure the fuel cap is completely and securely closed after refueling to prevent spillage. Gasoline and diesel fuel are flammable and can cause fire, explosions, injury or death.
- WARNING:** Never operate this generator in a manner other than as described in this manual. Operation in any manner not described in this manual should be considered unsafe and should not be attempted. Never start the engine unless you have first verified that the installation and operation of the generator are as described in this manual.
- WARNING:** Be sure that you are completely familiar with the safe operation of this equipment. This equipment may be connected to other machines that have rotating parts or parts that are controlled by this equipment. Improper use can cause serious or fatal injury.
- WARNING:** Exhaust fumes/gases are extremely dangerous and can cause severe illness or death. Never breath exhaust fumes produced by a running engine. Only run the engine outdoors where ventilation is plentiful. Exhaust gases contain carbon monoxide, a colorless, odorless and extremely dangerous gas that can cause unconsciousness or death. Symptoms of carbon monoxide poisoning include: dizziness, nausea, headaches, sleepiness, vomiting or incoherence. If you or anyone else experiences these symptoms, get out into fresh air immediately. Stop the engine and do not restart the engine until it has been inspected and if necessary repaired or reinstalled in a well ventilated area.
- WARNING:** Hot exhaust gasses must never be directed toward anything that may catch fire or explode.
- WARNING:** This generator must not be used on or near any forest covered, brush covered, or grass covered land unless the engine's exhaust system is equipped with a spark arrestor. The spark arrestor must be maintained in effective working order by the operator.
- WARNING:** Some parts of this generator rotate during operation. Rotating parts can present extreme danger if clothing or body extremities are caught by the rotating part and can cause serious or fatal injury. Never touch a part of the generator until the engine has been stopped and all rotating parts are completely stopped. Also, disconnect the spark plug wires and battery connection to prevent accidental engine rotation during servicing.
- WARNING:** Never move a generator set that is running. Loads should be connected and position secure before starting the engine. Hazards are caused by moving a generator set that is running.

Continued on next page.

Operation Warning Statements Continued

- WARNING:** Be sure that you understand how to stop the engine quickly in case of an emergency situation. Become familiar with the controls and safety systems provided with this generator set.
- WARNING:** Always wear safety glasses with side shields and hearing protection when working near the generator.
- WARNING:** Improper operation may cause violent motion of connected equipment. Be certain that unexpected movement will not cause injury to personnel or damage to equipment.
- WARNING:** Never operate the generator set indoors or in a poorly ventilated area such as a tunnel or cave. Exhaust fumes are extremely dangerous to all personnel that are in or in contact with that area.
- WARNING:** Never permit anyone to operate the generator without proper instructions. Be sure to keep a copy of this manual with the generator so that all users can be properly informed of its safe operation.
- WARNING:** Never allow children or pets to be in the area where the generator is running. The generator and the equipment being powered by the generator may cause injury or death.
- WARNING:** Never operate the generator unless all guards, covers, shields and other safety items are properly installed.
- WARNING:** Do not put hands, feet, tools clothing or other objects near rotating parts such as drive shaft, pulley, belt etc. Rotating parts cause extremely dangerous situations because they can catch loose clothing or extremities and cause serious or fatal injury.
- WARNING:** When operating this generator remain alert at all times. Never operate machinery when physically or mentally fatigued, or while under the influence of alcohol, drugs or medication.
- WARNING:** Never operate the engine when the air cleaner is removed. An engine backfire can cause serious burns.
- WARNING:** Never “jump start” a generator to start the engine. If the battery charge is insufficient to start the engine, charge or replace the battery and try to restart. Jump starting a battery can cause the battery to explode and cause severe injury or death to anyone in the area.
- WARNING:** High voltage is present whenever engine is running. Electrical shock can cause serious or fatal injury. Never operate electrical equipment while standing in water, on wet ground or with wet hands, feet or shoes or while barefoot.
- WARNING:** High voltage is present whenever the engine is running. Electrical shock can cause serious or fatal injury. Always stop engine before connecting or disconnecting power cords or external devices.
- WARNING:** Do not smoke near generator during operation or while refueling. Gasoline and diesel fuel are flammable and can cause fire, explosions, injury or death.
- WARNING:** Stop engine and allow engine to cool before refueling. Gasoline and diesel fuel are flammable and can cause fire, explosions, injury or death.
- WARNING:** Never store the generator with fuel in the tank. Never store the generator indoors or in an enclosed area or in a poorly ventilated enclosure where fumes may reach an open flame, electrical spark or pilot light as on a furnace, water heater, clothes dryer, etc. Gasoline and diesel fuel are flammable and can cause fire, explosions, injury or death.
- WARNING:** Allow generator to cool before transporting it or storing it. Always drain fuel from tank after generator has cooled.
- WARNING:** When transporting the generator (especially over rough roads) always drain the fuel tank to prevent leakage or spillage of fuel. Gasoline and diesel fuel are flammable and can cause fire, explosions, injury or death.
- WARNING:** Operate the generator only on a level surface. If the generator is tilted during operation, fuel spillage may result. Gasoline and diesel fuel are flammable and can cause fire, explosions, injury or death.
- WARNING:** Keep generator at least three feet away from buildings and other structures.
- WARNING:** Keep generator away from flammable or hazardous materials (trash, rags, lubricants, explosives, paints etc.) and grass or leaf build up.
- WARNING:** Keep a fire extinguisher near the generator while generator is in use. An extinguisher rated “ABC” by the National Fire Protection Association is appropriate.

Continued on next page.

Warning Statements Continued

Burn

WARNING: Parts of this generator are extremely hot during and after operation. To prevent severe burns, do not touch any part of the generator until you have first determined if the part is hot. Wear protective clothing and after use allow sufficient time for parts to cool before touching any part of the generator.

WARNING: Do not touch the hot exhaust parts or the high voltage spark plug or coil terminals of the engine. Although spark plug voltages are not normally lethal, a sudden involuntary jerk of the hand or body part caused by contact with high voltage or a hot surface can result in injury to yourself or others.

Installation

WARNING: Installation and repair procedures requires specialized skills with electrical generating equipment and small engine systems. Any person that installs or performs repairs must have these specialized skills to ensure that the generator set is safe to operate. Contact Baldor for installation or repairs.

WARNING: Be sure all wiring complies with the National Electrical Code (NEC) and all regional and local codes or CE Compliance. Improper wiring may cause a hazardous condition and exposure to electrical hazards can cause serious injury or death.

WARNING: Be sure the system is properly grounded before applying power. Do not apply AC power before you ensure that grounds are connected. Electrical shock can cause serious or fatal injury. NEC requires that the frame and exposed conductive surfaces (metal parts) be connected to an approved earth ground. Local codes may also require proper grounding of generator systems.

WARNING: Place protective covers over all rotating parts such as drive shaft, pulley, belt etc. Rotating parts cause extremely dangerous situations because they can catch loose clothing or extremities and cause serious or fatal injury.

WARNING: Unauthorized modification of a generator set may make the unit unsafe for operation or may impair the operation of the unit. Never start a generator set that has been modified or tampered with. Be sure that all covers and guards are properly installed and that the unit is safe before starting the engine. If you are unsure, contact Baldor before starting the engine.

WARNING: When moving the generator, use reasonable caution. Be careful where you place fingers and toes to prevent injury "Pinch Points". Never try to lift a generator without a hoist or lift means because they are heavy and bodily injury may result.

WARNING: When transporting a generator (especially if it has wheel option installed) secure the unit to prevent movement during transport.

WARNING: Never connect this generator to any buildings electrical system unless a licensed electrician has installed an approved transfer switch. The National Electrical Code (NEC) requires that connection of a generator to any electrical circuit normally powered by means of an electric utility must be connected by means of approved transfer switch equipment so as to isolate the electrical circuit from the utility distribution system when the generator is operating. Failure to isolate the electrical circuits by such means may result in injury or death to utility power workers due to backfeed of electrical energy onto the utility lines.

WARNING: Circuit overload protection must be provided in accordance with the National Electrical Code and local regulations.

WARNING: Check Ground Fault Circuit Interrupt (GFCI) receptacles monthly by using the "Test" and "Reset" buttons.

WARNING: Only a professional experienced technician should install a fuel supply system. Gasoline and diesel fuel are flammable and can cause fire, explosions, injury or death. Fuel supply lines should be kept away from sharp objects to prevent rupture. Comply with all NFPA regulations and local codes for shut-off valves, regulators, fuel line type etc.

WARNING: Have electrical circuits and wiring installed and checked by licensed electrician or qualified technician. Electrical shock can cause serious or fatal injury.

WARNING: Incorrect installation of this generator set could result in property damage, injury or death. Connection of the generator to its fuel source must be done by a qualified professional technician or contractor.

Continued on next page.

Warning Statements Continued

Maintenance

- WARNING:** Before servicing the generator set, be sure to disconnect the spark plugs and battery terminals to prevent accidental engine rotation or starting.
- WARNING:** Before cleaning, inspecting, repairing, refueling or performing any maintenance to the generator set, always be sure the engine has stopped and that all rotating parts have also stopped. After stopping, certain components are still extremely hot so be careful not to get burned. Before servicing the generator set, be sure to disconnect the spark plug wires and the battery terminals to prevent accidental engine rotation or starting.
- WARNING:** Engine coolant is under pressure and is near the boiling point of water when engine is hot. Do not open the coolant system until the engine has completely cooled. Hot coolant can cause severe burns and other injuries. When engine is cool, coolant level can be checked.
- WARNING:** Before servicing the generator set, be sure to disconnect the spark plug wires and the battery terminals to prevent accidental engine rotation or starting.
- WARNING:** Inspect all wiring frequently and replace any damaged, broken or frayed wiring or wires with damaged insulation immediately. Electrical shock can cause serious or fatal injury.
- WARNING:** Disconnect all electrical wires and load devices from generator power outlets before servicing the generator. Electrical shock can cause serious or fatal injury. Always treat electrical circuits as if they are energized.
- WARNING:** Check all fuel tanks, supply piping, and their connections monthly for fuel leaks. Gasoline and diesel fuel are flammable and can cause fire, explosions, injury or death. If a leak is found, replace only with approved pipe or components.
- WARNING:** A battery presents a risk of fire and explosion because they generate hydrogen gas. Hydrogen gas is extremely explosive. Never jump start a battery, smoke in the area around the battery or cause any spark to occur in the area around the battery.
- WARNING:** Do not mutilate the battery or dispose of a battery in a fire. The battery is capable of exploding. If the battery explodes, electrolyte solution will be released in all directions. Battery electrolyte solution is caustic and can cause severe burns and blindness. If electrolyte contacts skin or eyes, immediately flush the area with water and seek medical attention quickly.
- WARNING:** A battery presents a risk of electrical shock hazard and high short circuit current. Electrical shock can cause serious or fatal injury. Never wear jewelry, watch or any metal objects when in the area around the battery.
- WARNING:** The battery electrolyte is a dilute sulfuric acid that is harmful to the skin and eyes. It is electrically conductive and corrosive. If electrolyte contacts the skin, flush the area immediately with water and wash it off using soap and water. If electrolyte contacts the eyes, immediately flush the eye thoroughly with water and seek medical attention quickly.
- WARNING:** The capacitor used in this generator can store and discharge a high voltage charge. Before working with or in the area of the capacitor, discharge the capacitor by shorting its leads together with a screwdriver with an insulated handle or insulated jumper wire.
- WARNING:** Be extremely careful when flashing the generator. When the alternator cover is removed rotating parts and high voltage are present. Electrical shock can cause serious or fatal injury. Rotating parts can present extreme danger if clothing or body extremities are caught by the rotating part and can cause serious or fatal injury.
- WARNING:** Never store an engine with fuel in its tank indoors or in an enclosed, poorly ventilated area where gasoline fumes could reach an ignition source and cause an explosion.

Continued on next page.

Caution Statements

- Caution:** The brass connecting tab on some 120VAC duplex receptacles have been removed. Each receptacle is powered by a separate generator winding. When replacing a receptacle, inspect the brass tab that normally links both receptacles. If it is removed, be sure to remove the brass tab from the replacement receptacle before it is installed. Failure to remove the tab will cause a direct short to the generator windings and cause possible generator damage.
- Caution:** Avoid installing the generator set beside heat generating equipment, or directly below water or steam pipes or in the vicinity of corrosive substances or vapors, metal particles and dust. Heat can cause engine problems to develop and unwanted substances can cause rust or generator failure over time.
- Caution:** Do not apply high voltage to windings in a moisture-saturated condition. Moisture can cause insulation breakdown, making it necessary to return the generator to the factory for repair, and consequent expense and loss of time.
- Caution:** Use only original equipment or authorized replacement parts. Using the correct parts will assure continued safe operation as designed.
- Caution:** Do not support the generator from the top of the wrap frame.
- Caution:** Do not tamper with or change the engine speed. Engine speed is factory set to produce the correct voltage and output frequency.
- Caution:** Never operate the engine without a muffler. The engine is designed to have the correct exhaust components installed and operating without these components can present a fire hazard, cause excessive exhaust gases and cause damage to engine. Inspect muffler periodically and replace if necessary.
- Caution:** Operate the generator only on a level surface. Operation of the generator on an incline or slope may degrade engine lubrication and result in engine failure.
- Caution:** Always fill fuel tank with clean fresh fuel before use. Never leave fuel in tank for long storage periods. Old fuel becomes stale and can damage the fuel system causing the engine not to start. Always drain the fuel tank after use before storage.
- Caution:** For electric start models, do not place the key switch in the start position when engine is running. This causes the starting motor to engage and may damage the starter and engine.
- Caution:** The PC90VE generator must have a battery installed for operation. The battery is used during starting and during operation. If engine operation is attempted while the battery is removed, damage to the engine's electrical components may result.

Section 2 General Information

Thank you for purchasing your Baldor Generator Set. This manual contains information you need to safely and efficiently install and operate your generator set. During the preparation of this manual every effort was made to ensure the accuracy of its contents. This manual describes only very basic engine information. A separate owner's manual for the engine is supplied with this unit for your use. Please refer to the engine manual for information relative to engine operation, maintenance, recommendations and additional safety warnings.

Copyright Baldor © 2004. All rights reserved.

This manual is copyrighted and all rights are reserved. This document may not, in whole or in part, be copied or reproduced in any form without the prior written consent of Baldor Electric Company, Inc.

Baldor Generators have earned the reputation of being high quality and dependable. We take pride in this fact and continue to keep our quality standards high on our list of priorities. We are also constantly researching new technological ideas to determine if they could be used to make our generator sets even better.

Baldor makes no representations or warranties with respect to the contents hereof and specifically disclaims any implied warranties of fitness for any particular purpose. The information in this document is subject to change without notice. Baldor assumes no responsibility for any errors that may appear in this document.

Limited Warranty

Baldor Generators will replace or repair free of charge any part or parts of the generator of their manufacture that are defective in workmanship and materials for a period of time as set forth in the Warranty Period chart below. All Baldor products requiring warranty service shall be transported or shipped freight pre-paid, at the risk of the party requiring warranty service, to a Baldor Generator repair facility, or to Baldor Generators Customer Service Department in Oshkosh, Wisconsin. Written notification of the alleged defect in addition to a description of the manner in which the Baldor generator is used, and the name, address and telephone number of the party requiring warranty service must be included. Baldor is not responsible for removal and shipment of the Baldor product to the service center or for the reinstallation of the Baldor product upon its return to the party requiring warranty service. Problems with Baldor products can be due to improper maintenance, faulty installation, non-Baldor additions or modifications, or other problems not due to defects in Baldor workmanship or materials. If a Baldor Generator repair facility determines that the problem with a Baldor product is not due to defects in Baldor workmanship or materials, then the party requesting warranty service will be responsible for the cost of any necessary repairs. EXCEPT FOR THE EXPRESSED WARRANTY SET FORTH ABOVE, BALDOR GENERATORS DISCLAIMS ALL OTHER EXPRESSED AND IMPLIED WARRANTIES INCLUDING THE IMPLIED WARRANTIES OF FITNESS FOR A PARTICULAR PURPOSE AND MERCHANTABILITY. NO OTHER WARRANTY, EXPRESSED OR IMPLIED, WHETHER OR NOT SIMILAR IN NATURE TO ANY OTHER WARRANTY PROVIDED HEREIN, SHALL EXIST WITH RESPECT TO THE GOODS SOLD UNDER THE PROVISIONS OF THESE TERMS AND CONDITIONS. ALL OTHER SUCH WARRANTIES ARE HEREBY EXPRESSLY WAIVED BY THE BUYER. UNDER NO CIRCUMSTANCES SHALL BALDOR GENERATORS BE LIABLE OR RESPONSIBLE IN ANY MANNER WHATSOEVER FOR ANY INCIDENTAL, CONSEQUENTIAL OR PUNITIVE DAMAGES, OR ANTICIPATED PROFITS RESULTING FROM THE DEFECT, REMOVAL, REINSTALLATION, SHIPMENT OR OTHERWISE. This is the sole warranty of Baldor Generators and no other affirmations or promises made by Baldor Generators shall be deemed to create an expressed or implied warranty. Baldor Generators has not authorized anyone to make any representations or warranties other than the warranty contained herein.

Warranty Period

Generator Series	Labor*	Parts
Portable Products (Premier, Powerchief, DG Series, K Series)	1 Year	3 Years
Towable Products (TS)	1 Year or 3,000 Hours Whichever comes first	3 Years or 3,000 Hours Whichever comes first
3600 RPM Standby Systems (Some AE Models)	1 Year or 1,000 Hours Whichever comes first	3 Years or 1,000 Hours Whichever comes first
1800 RPM Standby Systems (Some AE Models, DLC, GLC)	1 Year or 3,000 Hours Whichever comes first	3 Years or 3,000 Hours Whichever comes first
Industrial Standby Systems	1 Year or 1,000 Hours Whichever comes first	2 Years or 1,000 Hours Whichever comes first
Industrial Prime Power Systems	1 Year or 1,000 Hours Whichever comes first	1 Year or 1,000 Hours Whichever comes first
International	1 Year or 1,000 Hours Whichever comes first	1 Year or 1,000 Hours Whichever comes first

*For products covered under labor coverage, travel expenses will be allowed up to 7 hours straight labor or 300 miles, whichever occurs first and only applies to permanently wired and mounted products (AE, DLC, GLC, IDLC). No warranty registration card is necessary to obtain warranty on Baldor Generators.

You must save the purchase receipt. Proof of purchase, date, serial number and model number will be required for all portable and Towable products to qualify for any warranty consideration.

For all other products, a start-up inspection form/warranty registration must be completed in its entirety and submitted to Baldor Generators within 30 days of start-up to qualify for any warranty consideration.

LIMITED WARRANTY ON EVAPORATIVE EMISSION CONTROL SYSTEMS – CALIFORNIA ONLY

The California Air Resources Board (CARB) and Baldor Generators (herein "Baldor") are pleased to explain the Evaporative Emission Control System (EECS) warranty on your model year 2006 and later generator. In California, new generators must be designed, built and equipped to meet the State's stringent anti-smog standards. Baldor must warrant the EECS on your generator for the period of time listed below provided there has been no abuse, neglect or improper maintenance of your generator. Your EECS may include parts such as the carburetor, fuel-injection system, ignition system, catalytic converter, fuel tanks, fuel lines, fuel caps, valves, canisters, filters, vapor hoses, camps, connectors, and other associated emission-related components. Where a warrantable condition exists, Baldor will repair your generator at no cost to you including diagnosis, parts and labor for the time period set forth below.

BALDOR EVAPORATIVE EMISSION CONTROL SYSTEM DEFECTS WARRANTY COVERAGE

This evaporative emission control system is warranted for a period of two (2) years, subject to the provisions set forth below. If any covered evaporative emission-related part on your equipment is defective, the part will be repaired or replaced by Baldor.

OWNER'S WARRANTY RESPONSIBILITIES

As the generator owner, you are responsible for performance of all the required maintenance listed in your owner's manual. Baldor recommends that you retain all receipts covering maintenance on your generator, but Baldor cannot deny EECS warranty claims solely for the lack of receipts. As the generator owner, you should however be aware that Baldor may deny you warranty coverage if your generator or a part has failed due to abuse, neglect, or improper maintenance or unapproved modifications. You are responsible for presenting your generator to an authorized Baldor service center as soon as the problem exists. The warranty repairs should be completed in a reasonable amount of time, not to exceed 30 days from the date of delivery to the authorized Baldor service center. If you have a question regarding your warranty coverage, you should contact Baldor – Generator Technical Support at 1-479-646-4711.

CONDITIONS AND RESTRICTIONS EVAPORATIVE EMISSIONS CONTROL SYSTEM WARRANTY COVERAGE

Baldor warrants to the ultimate purchaser and each subsequent purchaser that the generator is: (1) designed, built and equipped so as to conform with all applicable CARB EECS regulations; (2) free from defects in materials and workmanship that cause the failure of a warranted part to be identical in all material respects to that part as described in Baldor's application of certification to CARB; (3) the warranty period begins on the date the generator is delivered to an ultimate purchaser or first placed into service. The warranty period is two years.

Subject to certain conditions and exclusions as stated below, the warranty on EVAP emission-related parts is as follows: Any warranted part that is not scheduled for replacement as required maintenance in the written instructions supplied, is warranted for the warranty period. If the part fails during the period of warranty coverage, the part will be repaired or replaced by Baldor at an authorized Baldor service center at no charge to the owner. Any such part repaired or replaced under warranty will be warranted for the remainder of the EECS warranty period. Any warranted part that is scheduled only for regular inspection in the written instructions supplied is warranted for the EECS warranty period. Any such part repaired or replaced under warranty will be warranted for the remaining EECS warranty period. Any warranted part that is scheduled for replacement as required maintenance in the written instructions supplied is warranted for the period of time before the first scheduled replacement date for that part. If the part fails before the first schedule replacement, the part will be repaired or replaced by Baldor. Any such part repaired or replaced under warranty will be warranted for the remainder of the period prior to the first scheduled replacement point for the part. Notwithstanding the provisions herein, EECS warranty services or repairs will be provided at designated service facilities to service the subject equipment. The generator owner will not be charged for diagnostic labor that leads to the determination that an EECS warranted part is defective, if the work is performed at an authorized Baldor service center. Baldor is liable for damages to other Baldor generator equipment components proximately caused by a failure under warranty of any EECS warranted part. Throughout the EECS warranty period, Baldor will maintain a supply of EECS warranted parts sufficient to meet the expected demands for such parts. Any replacement part may be used in the performance of any EECS warranty maintenance or repairs and must be provided without charge to the owner. Such use will not reduce the warranty obligations of Baldor. Add-on or modified parts that are not exempted by the California Air Resources Board may not be used. The use of any non-exempted add-on or modified parts by the ultimate purchaser will be grounds for disallowing warranty claims. Baldor will not be liable to warrant failures of warranted parts caused by the use of a non-exempted add-on or modified part. This limited warranty does not cover any part which malfunctions, fails or is damaged due to failure to follow the maintenance and operating instructions provided with the generator.

EVAPORATIVE EMISSIONS CONTROL SYSTEM WARRANTED PARTS: The repair or replacement of any warranted part otherwise eligible for warranty coverage may be excluded from such warranty coverage if Baldor demonstrates that the generator has been abused, neglected, or improperly maintained, and that such abuse, neglect, or improper maintenance was the direct cause of the need for repair or replacement of the part. That notwithstanding, any adjustment of a component that has a factory installed, and properly operating, adjustment-limiting device is still eligible for warranty coverage. Parts covered under the California Evaporative Emissions Warranty are (1) low permeation fuel lines and fittings.

Section 3 Receiving & Installation

- Receiving & Inspection** When you receive your generator, there are several things you should do immediately.
1. Observe the condition of the shipping container and report any damage immediately to the commercial carrier that delivered your system.
 2. Verify that the part number of the system you received is the same as the part number listed on your purchase order.
 3. If the system is to be stored for several weeks before use, be sure that it is stored in a location that conforms to published storage temperature and humidity specifications. (Refer to Section 9 of this manual).

Lifting the Generator

When lift or hoist equipment is used to lift the generator and move it to position, be careful not to contact overhead wires or other obstacles. The generator weighs between 100 and 300 lbs. Use proper lift equipment and methods to avoid injury. Lift only by the tubular metal frame.

Figure 3-1 Powerchief® Generators



Storage

If you will not be using the generator set for a significant amount of time (3 months or longer) you should store the generator to prevent any problems that could arise from sitting idle. Please fully read the following guidelines prior to storing the unit.

1. Remove all fuel from the engine's fuel tank.
2. Start the generator set and allow it to run out of fuel.
3. Close all the fuel valves.

Note: An alternative to draining the fuel from a gasoline engine is adding a fuel stabilizer, to minimize the formation of fuel gum deposits during storage (Follow the manufacturer's directions). After the fuel stabilizer is added, run the generator set for 5 minutes to get the stabilizer into the carburetor. After shutting the engine off, be sure to close all the fuel valves.

4. Disconnect and remove the battery if your generator set is so equipped.
5. Drain the used oil from the engine's crankcase and refill it with clean oil.
6. Remove the spark plugs and pour 1 oz. of clean engine oil into each cylinder. Put a rag over each spark plug port and turn the engine over approximately 5 times to distribute the oil in the cylinder.
7. Replace the spark plug(s) but do not connect the plug wires. This will help prevent accidental or unauthorized starting.
8. Provide maintenance to the engine and generator set as described in the engine and generator maintenance sections of this manual.
9. Cover any bare metal spots with paint or another type of rust preventative.

WARNING: Never store an engine with fuel in its tank indoors or in an enclosed, poorly ventilated area where gasoline fumes could reach an ignition source and cause an explosion.

Physical Location

The mounting location of the system is important. It should be installed in an area that is protected from direct harmful gases or liquids, dust, metallic particles, shock and vibration. It can only be installed in an outdoor location so the exhaust fumes are vented to the atmosphere. This system must never be installed inside an enclosed building, home, shop or garage etc.

Several other factors should be carefully evaluated when selecting a location for installation:

1. For effective cooling and maintenance, the generator should be mounted on a flat, smooth, non-flammable level surface. A concrete pad is ideal and provides a secure installation.
2. The location for the generator must be dry. Never operate a generator in an area that has standing water or puddles.
3. Installation should prevent obstructions by buildup of leaves, grass, sand, snow, etc. It is important that the unit be operated in a reasonably clean environment.
4. All engines give off considerable heat when running. The engine in your generator set uses air to keep it cool so it is important that the ambient temperature is cool and does not exceed 100°F (even while it is running). Where natural ventilation is inadequate a fan to boost circulation should be used.
5. Exhaust gases from internal combustion engines are extremely poisonous. Never operate an engine indoors.

WARNING: Exhaust fumes/gases are extremely dangerous and can cause severe illness or death. Never breath exhaust fumes produced by a running engine. Only run the engine outdoors where ventilation is plentiful. Exhaust gases contain carbon monoxide, a colorless, odorless and extremely dangerous gas that can cause unconsciousness or death. Symptoms of carbon monoxide poisoning include: dizziness, nausea, headaches, sleepiness, vomiting or incoherence. If you or anyone else experiences these symptoms, get out into fresh air immediately. Stop the engine and do not restart the engine until it has been inspected and if necessary repaired or reinstalled in a well ventilated area.

6. All electrical equipment should be protected from excessive moisture. Failure to do so will result in deterioration of the insulation and may result in short circuits and a possible electrocution hazard.

Installation

The generator is completely assembled, tested and adjusted at the factory before it is shipped to you. External connections required at the time of installation are:

Note: The generator is shipped dry. This means no oil is in the engine crankcase and no battery is installed. You must refer to the engine manual and obtain the correct type and quantity of engine motor oil and the correct battery (if equipped for electric start).

1. Electrical Connections.
2. Ground Connection.

After installation, the post installation checks must be performed prior to starting the engine.

After these checks have been performed and the system operation is verified to be good, refer to Section 6 Maintenance for periodic checks that must be performed at scheduled intervals to ensure continued operation with minimal problems.

Electrical Connections All load connections are made at the panel using electrical cords with the proper mating plug for the receptacle being used. More than one receptacle can be used as long as the total load does not exceed the continuous rating of the generator.

WARNING: Never connect this generator to any buildings electrical system unless a licensed electrician has installed an approved transfer switch. The National Electrical Code (NEC) requires that connection of a generator to any electrical circuit normally powered by means of an electric utility must be connected by means of approved transfer switch equipment so as to isolate the electrical circuit from the utility distribution system when the generator is operating. Failure to isolate the electrical circuits by such means may result in injury or death to utility power workers due to backfeed of electrical energy onto the utility lines.

Use correct size insulated wire to connect the generator to the load. The gauge of the wire will depend on the distance to the load, the permissible voltage drop at the load, and the current required by the load. If you are not sure of the gauge wire needed for your application, consult a competent electrician. Using wire that is too small can result in fire hazard. Also, be sure the wire has the appropriate ratings for insulation and environment conditions.

The correct mating connector must be used to fit the connectors provided on the operator panel of your generator. Table 3-1 describes the connector types provided (receptacles) and the load characteristics to help you choose the correct size wire. Figure 3-2 shows the receptacles.

Electrical Connections Continued

Table 3-1 Single Phase Power Receptacle Description

Model	Electrical Connection Information (Receptacle Provided at Panel)			
	Straight 120VAC (20Amp)	Twist Lock 120VAC (30Amp)	Twist Lock 120/240VAC (30Amp)	Rated Watts/ (Full load Amps 120/240)
PC30H	3- 15AMP 120VAC			3000 / (22.5/-)
PC40H	2- 5-20R GFCI 120VAC	1- L5-30R 120VAC	1- L14-30R 120/240VAC	4000 / (33.3/16.7)
PC50H	2- 5-20R GFCI 120VAC	1- L5-30R 120VAC	1- L14-30R 120/240VAC	5000 / (33.3/16.7)
PC60H	2- 5-20R GFCI 120VAC	1- L5-30R 120VAC	1- L14-30R 120/240VAC	6000 / (45.8/22.9)
PC90VE	2- 5-20R GFCI 120VAC	1- L5-30R 120VAC	1- L14-30R 120/240VAC	9000 / (66.7/33.4)

Note: GFCI is Ground Fault Protected power.

Class 1 wiring methods must be used for field wiring connections to terminals of a Class 2 circuit.

Figure 3-2 Receptacle Connections

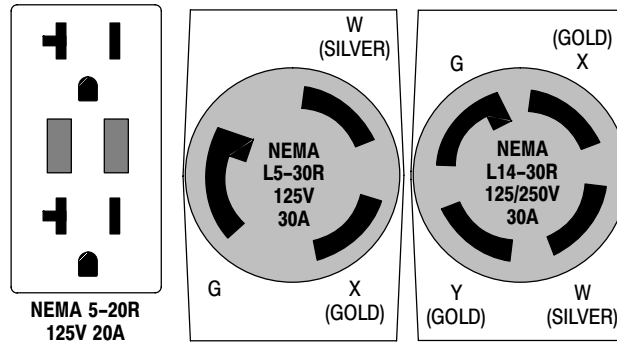

Frame Ground Connection

WARNING: Be sure the system is properly grounded before applying power. Do not apply AC power before you ensure that grounds are connected. Electrical shock can cause serious or fatal injury. NEC requires that the frame and exposed conductive surfaces (metal parts) be connected to an approved earth ground. Local codes may also require proper grounding of generator systems.

The NEC requires that the frame and exposed metal surfaces be at local ground reference potential to avoid electrical shock hazard. A local ground reference may require a driven earth ground conductor at the generator installation site. Make the ground connection as shown in Figure 3-3. Use the appropriate size wire (normally 6 AWG) as required by NEC and local codes. The local reference ground is normally a copper clad earth ground rod driven into the earth at least 8 feet.

Frame Ground Connection Continued

Figure 3-3 Frame Ground Connection

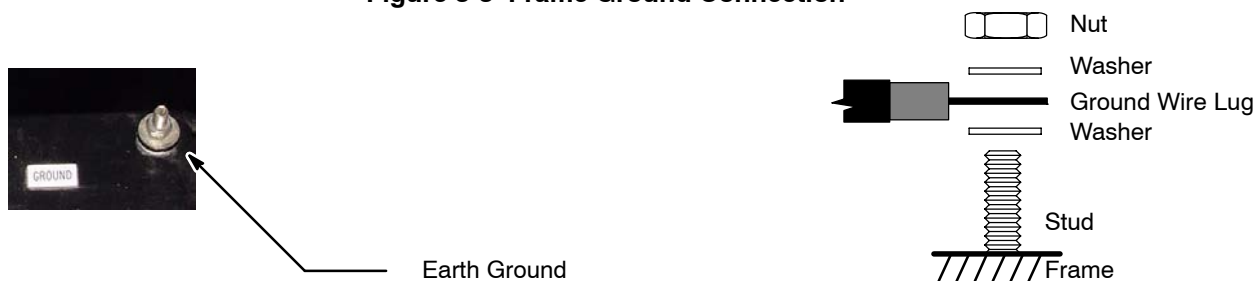

Engine Oil

Refer to the engine manual that was provided with your generator. Determine the correct type of engine oil and the amount specified by the engine manufacturer. Add the required amount of oil to bring the oil level to full.

Caution: The PC90VE generator must have a battery installed for operation. The battery is used during starting and during operation. If engine operation is attempted while the battery is removed, damage to the engine's electrical components may result.

Battery Connections Applies to 12VDC Electric Start models only. The generator is shipped with no battery installed.

Note: PC90VE units that have an electronic governor must have a battery installed before the Genset can be started (even with the pull starter). If no battery is present or the battery is discharged, the electronic governor will not operate and the generator set will not run.

WARNING: Do not dispose of battery or batteries in a fire. The battery is capable of exploding. If the battery explodes, electrolyte solution will be released in all directions. Battery electrolyte solution is caustic and can cause severe burns and blindness. If electrolyte contacts skin or eyes, immediately flush the area with water and seek medical attention quickly.

WARNING: Do not mutilate the battery. The battery contains electrolyte solution which is caustic and can cause severe burns and blindness. If electrolyte contacts skin or eyes, immediately flush the area with water and seek medical attention quickly.

WARNING: A battery presents a risk of electrical shock hazard and high short circuit current. The following precautions are to be followed when working on batteries:

1. Remove watches, rings, necklaces and all other metal objects.
2. Use tools with insulated handles.
3. Wear rubber gloves and boots.

WARNING: The battery electrolyte is a dilute sulfuric acid that is harmful to the skin and eyes. It is electrically conductive and corrosive. The following precautions are to be followed when working on batteries:

1. Wear full eye protection (safety glasses or goggles) and protective clothing.
2. Where electrolyte contacts the skin, flush the area immediately with water and wash it off using soap and water.
3. Where electrolyte contacts the eyes, immediately flush the eye thoroughly with water and seek medical attention quickly.
4. Spilled electrolyte is to be washed down with an acid neutralizing agent. A common practice is to use a solution of one pound (500 grams) bicarbonate of soda to one gallon (four liters) of water. the bicarbonate solution is to be added until evidence of reaction (foaming) has ceased. The resulting liquid is to be flushed with water and the area dried.

WARNING: A battery presents a risk of fire because they generate hydrogen gas. Hydrogen gas is extremely explosive. Never jump start a battery, smoke in the area around the battery or cause any spark to occur in the area around the battery. The following precautions are to be followed when working on batteries:

1. Do not smoke when near batteries.
2. Do not cause flame or spark in battery area.
3. Discharge static electricity from body before touching batteries by first touching a grounded metal surface.

Battery Connections Continued

Note: PC90VE units that have an electronic governor must have a battery installed before the Genset can be started (even with the pull starter). If no battery is present or the battery is discharged, the electronic governor will not operate and the generator set will not run.

- Procedure:** The correct type battery must be purchased and installed in the battery compartment provided.
1. Remove the bag containing the battery box components.
 2. Set the battery on the battery tray.
 3. Install the battery hold down rods as shown in Figure 3-4.
 - a. Place the bent end of the battery hold down rod through the hole in the battery tray.
 - b. Place the threaded end of the battery hold down rod through the hole in the battery hold down bar and secure with flat washer, lock washer and nut.
 - c. Repeat steps a and b for the other battery hold down rod.
 4. Connect the battery cables to the battery, be sure the Positive lead is connected to the positive (+) battery terminal and the negative lead is connected to the positive (-) battery terminal.

Figure 3-4 Battery Installation

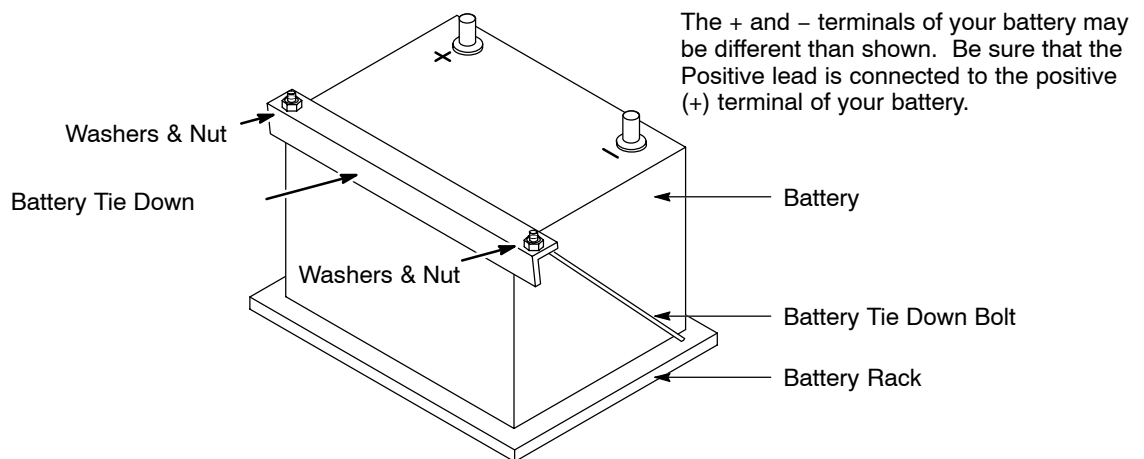

Use of Electric Motor Loads

Electric motors require much more current (amperes) to start them than to keep them running. Some motors, particularly split-phase motors are very difficult to start and require 5 to 7 times more current to start them. Repulsion-induction type motors are the easiest to start and normally only require 2 to 3 times as much current to start them.

Most fractional horsepower motors take about the same amount of current to start them and keep them running. This is true whether they are the repulsion-induction type motor, capacitor type motor, or the split-phase type motor.

Other factors that influence the amount of current needed to start a motor are:

1. **The type of load connected to the motor.** If the electric motor is connected to a hard starting load such as an air compressor it will require more starting current. If the same electric motor is connected to a light load such as a heater or power saw it will require less starting current.
2. **The brand or design of the electric motor.** The expected starting current for a particular size motor will vary depending on the brand of the electric motor as well as the type of electric motor (Split Phase, capacitor, Repulsion-induction type, etc.)
3. **The condition of the electric motor.** A clean motor with free turning bearings will require less starting currents than a similar type motor that is dirty and the bearings are not as free turning as they used to be.

Optional Wheel Kit PDG2 – 2 Wheel Dolly Kit; and PDG4 – 4 Wheel Dolly Kit

An optional 2 or 4 wheel dolly kit is available for Powerchief portable generators. If you have purchased one of these kits, refer to MN2409 for the installation instructions.

Recommended Engine Oil and Battery Type

Series PC

MODEL	SUMMER OIL	WINTER OIL	OIL CAPACITY	RECOMMENDED BATTERY	(AMPS) COLD CRANKING
PC30H-17.10030	SAE. 30	5W/30	.85 PTS	N/A	N/A
PC50H-01,17.20050-01	SAE. 30	5W/30	1.90 PTS	N/A	N/A
PC60H-17.20060	SAE. 30	5W/30	2.0 PTS	N/A	N/A
PC60H-04, 17.20060-04	SAE. 30	5W/30	2.0 PTS	N/A	N/A
PC60HE-04, 17.20062-04	SAE. 30	5W/30	2.0 PTS	Interstate SP-40	340
PC90VE - 17.10090	SAE. 30	5W/30	2.0 PTS	Interstate SP-40	340

Section 4 Operation

Operator Control Panel

Each operator panel is slightly different, depending on features of the generator you purchased. The Operator Control Panel of Figure 4-1 is shown because it has most of the available features. This will be used to explain how the controls operate.

Figure 4-1 Operator Control Panels

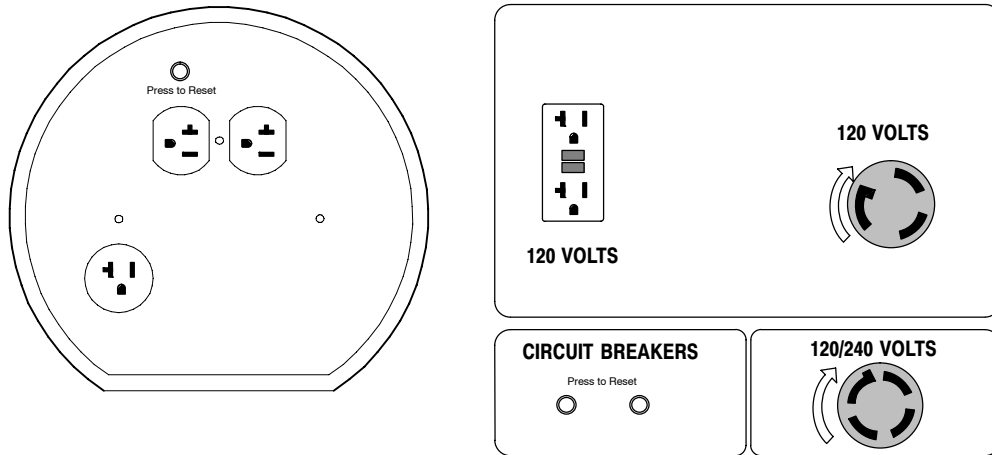

AC Circuit Breakers Provide overcurrent protection for the generator output. When tripped, the plunger (in center of breaker) will extend out about 3/8 inch. Remove the loads, push the plunger into the breaker to reset the breaker the restore the loads.

WARNING: Never connect this generator to any buildings electrical system unless a licensed electrician has installed an approved transfer switch. The National Electrical Code (NEC) requires that connection of a generator to any electrical circuit normally powered by means of an electric utility must be connected by means of approved transfer switch equipment so as to isolate the electrical circuit from the utility distribution system when the generator is operating. Failure to isolate the electrical circuits by such means may result in injury or death to utility power workers due to backfeed of electrical energy onto the utility lines.

Receptacles – Receptacles are provided to allow easy connection of electrical loads. Never connect this generator to any buildings electrical system unless a licensed electrician has installed an approved transfer switch. Multiple receptacles may be used at the same time provided the total electrical load does not exceed the generators rated output.

120Volts – PC30H has no GFCI protection, 3 outlets rated 125VAC at 15 Amperes. All others have NEMA 5–20R GFCI Duplex receptacle provides ground fault protection. Rated 125VAC at 20 Amperes.

30 Amps 120 Volts – Twist lock NEMA L5–30R receptacle, rated 125 Volts at 30 Amperes.

30 Amps 120/240 Volts – Twist lock NEMA L14–30R receptacle rated 250Volts at 30 Amperes.

Note: The nominal voltage produced by the generator at each receptacle is 120VAC or 240VAC.

Pre-Start Checks Before the engine is started, several things must first be checked.

1. Place the generator set in an open, dry, well ventilated and reasonably level location.
2. If grounding is required for your application, check to make sure your unit is grounded properly (see Section3).
3. Check the engine's oil level and add oil if necessary to bring it to the level recommended by the engine manufacturer.
4. Check the fuel level and add fuel to within 1/2 inch of the fill tube if necessary.
5. Open the fuel valve on the fuel tank.
6. Check the fuel system for fuel leaks and repair them prior to starting the engine. Wipe up any fuel spills before starting the engine.
7. Disconnect or "turn off" all external loads.
8. Make sure all circuit breakers are set (pushed in).
9. Tighten any bolts or nuts that may have loosened due to vibration.
10. Be sure all extension cords are in good condition before starting the generator. Use only U.L. listed extension cords.

Start-Up Procedure

Electric Start

1. Move the engine's choke lever to the "Choke/Start" position. If the engine is warm or if the ambient air temperature is high; try starting the engine without choking it.
2. Move the Control Panel Engine "ON/OFF" switch to "ON" (if equipped).
3. Engage the electric start motor.
(Push the engine's start switch or turn the key switch fully clockwise).
4. Do not allow the starter motor to crank for more than 10 seconds at a time.
5. Allow 20 seconds between starter motor cranking attempts.
6. Once the engine has started, release the start switch and do not re-engage it.

Note: If the engine does not start after a few attempts, smell for fuel near the air cleaner. If there is a significant gasoline smell, turn the choke lever off and attempt to start the engine.

7. When the engine starts, turn the engine's choke lever to the "OFF" position.
8. Power is now present at the receptacles.
Connect or "turn on" the loads you wish to operate.

Recoil Start

1. Move the engine's choke lever to the "Choke/Start" position. If the engine is warm or if the ambient air temperature is high; try starting the engine without choking it.
2. Move the Control Panel Engine "ON/OFF" switch to "ON" (if equipped).
3. Pull lightly on the recoil grip until you feel significant resistance, then pull sharply. Allow the recoil to gently rewind into the recoil housing. See your engine manual for instructions specific to your unit. Do not allow the recoil rope to "snap back" into the recoil housing.

Note: If the engine does not start after turning the engine over a few times, smell for fuel near the air cleaner. If there is a significant gasoline smell coming from the air cleaner, turn the choke lever off and attempt to start the engine with the choke off.

4. When the engine starts, turn the engine's choke lever to the "OFF" position.
5. Power is now present at the receptacles.
Connect or "turn on" the loads you wish to operate.

Stopping Procedure

1. Disconnect or "Turn Off" all loads connected to the generator set.
2. Move the Control Panel Engine "ON/OFF" switch to "OFF" (if equipped).
3. Push the engine stop switch if so equipped.
OR
Turn the engine key switch to the "OFF" position.
4. Turn all fuel valves off.

Section 5

Troubleshooting and Maintenance

Maintenance

This manual contains only very minimal engine maintenance instructions. Refer to the engine manufacturer's owner's manual for specific engine maintenance instructions for your generator set. Any maintenance instructions or recommendations in the engine owner's manual take precedence over any of the following general recommendations.

General:

1. Inspect the fuel system for leaks. Replace all defective components immediately.
2. Inspect and replace any fuel line that shows signs of deterioration.
3. Inspect all fuel clamps to ensure they are tight.
4. Make sure the fuel cap fits snugly on the fuel tank and that the fuel tank does not leak.
5. Inspect and clean the battery posts and the associated battery cable terminals.
6. Inspect the external wire cables and connectors used with the generator set for cuts, frayed insulation, or loose connections. Repair or replace damaged parts before use.
7. The engine should be checked for proper speed setting(s).
Prior to adjusting the engine speed, turn the auto idler switch to "OFF" (if present). Make sure that the auto idler magnet does not touch the throttle lever of the engine when running.
 - a. Disconnect all electrical loads and start the engine.
 - b. Adjust the engine speed to 3720 RPM (62 Hz) with no load speed.
 - c. Adjust the auto idler speed after you have accomplished the above adjustment.
 - d. Adjust the auto idler speed by moving the electro-magnet back and forth in the magnet bracket to achieve an engine RPM of 2500–2900 with the auto idler switch "ON".
8. Test all GFCI receptacles monthly by pressing the test button on the receptacle and making sure that the GFCI trips and no voltage is present at the receptacle. Replace any GFCI receptacle that fails the test.

Engine:

1. Clean and/or replace any fuel, oil, and/or air filters per the engine manufacturers' guidelines.
2. Check oil level regularly; at least every 5 to 8 operating hours. Maintain the proper oil level.
3. Change the oil as is recommended in the engine manufacturer's owner's manual.
4. Replace the spark plug(s) as is recommended by the engine manufacturer.
5. Clean the cooling fins on the engine to keep the engine's heat dissipation potential at its maximum.
6. Inspect and clean all governor and carburetor linkages so they operate properly.
7. Inspect the recoil starting rope for any damage and replace it if necessary (if applicable).
8. Clean the trash screen around the recoil starter or other cooling air intake.

Alternator: (also called Generator End)

This generator set must be run at its proper speed to obtain the correct electrical power at its output. All engines have a tendency to slow down when a load is applied to it. The engine governor is designed to hold the operating speed as nearly constant as possible. When the electrical load is increased, the engine is more heavily loaded and engine speed drops slightly. This slight decrease in engine speed results in a slight decrease in generator voltage and frequency output. This voltage and frequency variation has no appreciable effect in the operation of motors, lights, and most appliances and tools. However, timing devices and clocks will not keep perfect time when used on this generator.

1. Clean the generator set and remove any and all dust, dirt, or other foreign material.
2. Inspect and clean the cooling air intake and exhaust louvers of the generator end. Make sure they are clean. Remove dirt or any buildup that may restrict the cooling air flow.
3. Clean the generator set and its components with a damp cloth or sponge. Never use a water hose or pressure washer as this may damage electrical components.
4. Inspect and replace any control panel components that are broken or not working properly (receptacles, circuit breakers, switches, etc.)

Problems and Solutions

Some of the more common problems are listed in Table 5-1. This information is intended to be a check or verification that simple causes can be located and fixed. It is not an exhaustive “how to” for all types of problems. Procedures that require in depth knowledge or skills (like flashing the field) should be referred to the Baldor Generator Service Department by calling (920) 236-4200.

Table 5-1 Troubleshooting Guide

Problem	Possible Cause	Remedy
Engine will not start	No fuel. Restricted air flow. No spark.	Check that fuel valves are ON. Check fuel level in fuel tank. Check/replace air filter. Check/replace spark plug(s). Check that engine switch is in Start position.
Engine will not crank (electric start)	Dead battery.	Remove battery and trickle charge or replace with new battery. Never Jump Start.
Engine starts but will not run smoothly	Fuel or ignition problem	Refer to engine manual.
Engine overheats	Excessive load Debris or dirt buildup on engine	Remove one or more electrical loads. Remove debris. Clean engine surfaces to allow cooling.
No output voltage	Circuit Breaker tripped or defective. Loss of residual magnetism in exciter field poles. Open in stator windings Defective exciter circuit.	Reset circuit breaker or replace if required. Flash field. Check for continuity in windings. Return to factory for repair if open. Check/replace diode and capacitor and flash the field.
Output voltage varies	Irregular speed (fixed speed mode) Fluctuating speed (fixed speed mode) Loose terminal or load connections Defective bearing (uneven air gap)	Check engine for malfunction or load for fluctuation Stabilize load. The addition of a lamp load (resistance load) may compensate partially for load changes caused by intermittent motor operation. Do not overload. Verify all connections are proper and check tightness torque of terminals. Replace worn bearing
Low output voltage	Low engine speed Excessive load High resistance connections - connections will be warm or hot Shorted field Low power factor	Check that the Auto Idle switch is in OFF position. Check engine for malfunction or system for overload. Reduce load. Verify all connections are proper and check tightness torque of terminals. Test field coils for possible short by checking resistance with an ohmmeter or resistance bridge. Return rotor assembly to factory for repair if alternator field coils are shorted. Reduce inductive (motor) load. Some AC motors use about the same current regardless of load. Do not use motors of greater horsepower rating than is necessary to move the mechanical load.
High output voltage	Excessive speed (fixed speed mode)	Check engine for malfunction
Electrical shock when frame is touched	Static charge. Grounded armature or field coil.	Ground generator frame at local reference ground (see Section 3). Return to factory for repair
Mechanical noise	Defective bearing Rotor rubbing on stator Loose or misaligned coupling	Replace bearing Bad bearing - replace. Bent shaft - return to factory. Loose end bell - tighten; Loose drive Discs - tighten Tighten; align coupling and alternator shaft to engine shaft.

Service

Service for your generator can be obtained from Baldor Generators. Please have the following information available prior to contacting the factory:

The model number and serial number of the generator set.

A complete and accurate description of the problem.

Parts

Parts for your generator can be obtained from Baldor Generators. Please have the following information available prior to contacting the factory:

The model number and serial number of the generator set.

A complete and accurate description of the part (part number if known).

Note: Engine parts can usually be obtained from a local distributor by using the information in the engine manufacturer's owner's manual.

Appendix A

Powerchief® Series

Information in this Appendix applies to the following Baldor Generators:
PC30H, PC40H, PC50H, PC60H, PC90VE

Caution: The brass connecting tab on some 120VAC duplex receptacles have been removed. Each receptacle is powered by a separate generator winding. When replacing a receptacle, inspect the brass tab that normally links both receptacles. If it is removed, be sure to remove the brass tab from the replacement receptacle before it is installed. Failure to remove the tab will cause a direct short to the generator windings and cause possible generator damage.

Operator Panel Configuration

Figure A-1 PC30H Operator Panel

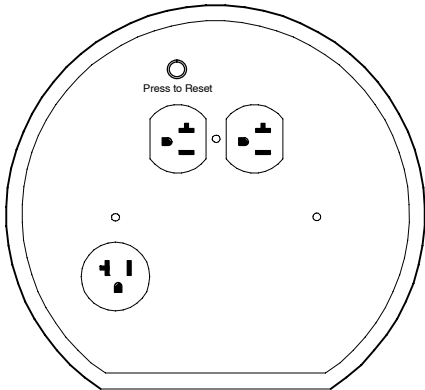

Duplex Receptacle.

Duplex receptacle is rated at 125VAC, 15 Amps.

Receptacle. Single style receptacle rated for 125VAC, 15 Amps.

Circuit Breaker.

Provide overload protection for the generator set.

Figure A-2 PC40H, PC50H, PC60H, PC90VE Operator Panel

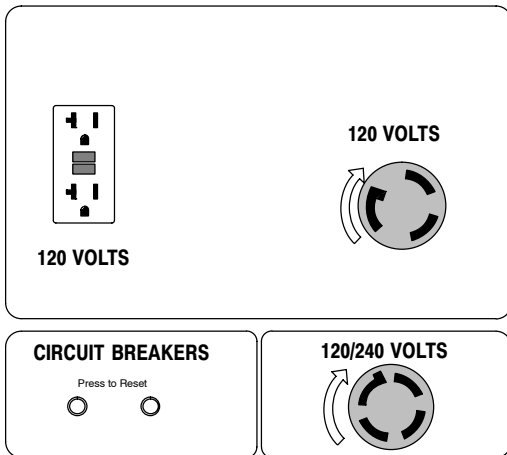

NEMA 5-20R GFCI Receptacle.

This ground fault circuit interrupter duplex receptacle is rated at 125VAC, 20 Amps.

NEMA L5-30R Receptacle. Twist-lock style receptacle rated for 125VAC, 30 Amps.

NEMA L14-30R Receptacle. Twist-lock style receptacle rated for 125/250VAC, 30 Amps.

Circuit Breakers.

Provide overload protection for the generator set.

Replacement Parts

Replacement parts assembly views for the Generator set are shown in Figure A-3 and A-4. Parts information is provided in Table A-1. Parts information for the engine is provided in the engine manual that was provided with your generator set. Please refer to the engine manual for replacement parts information.

Figure A-3 Alternator Assembly

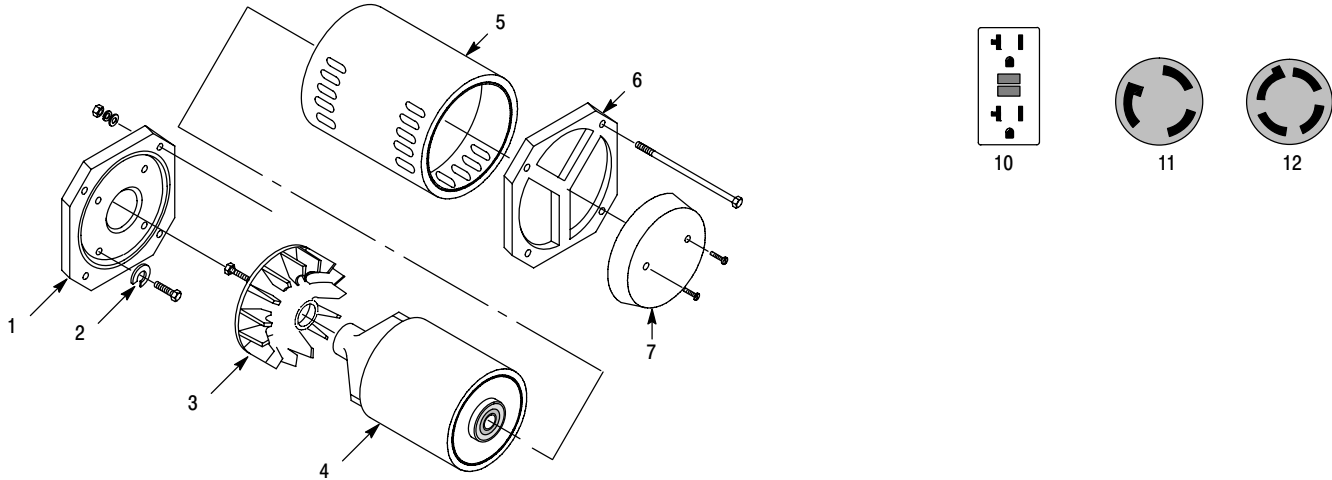

Figure A-4 Frame Assembly

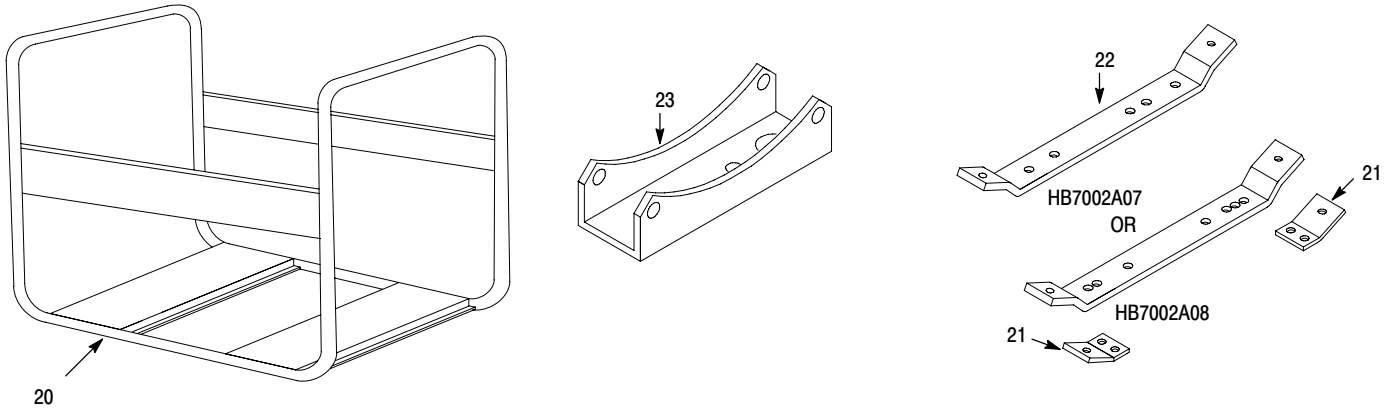

Table A-1 Generator Set Parts List

Ref No.	Part No.	Description	PC30H	PC40H	PC50H	PC60H	PC90VE
1	HA9139A00	Adaptor	X				
1	HA9139A01	Adaptor		X	X	X	X
2	HA1037A00	"C" Washer	X	X	X	X	X
3	61FN3000	Fan	X	X	X	X	X
4	61RA0011A00	Rotor Assembly (includes bearing)	X				
4	61RA0013A00	Rotor Assembly (includes bearing)		X	X		
4	61RA0015A00	Rotor Assembly (includes bearing)				X	
4	61RA0016A00	Rotor Assembly (includes bearing)					X
5	61SA0019A02	Stator Assembly	X				
5	61SA0010A04	Stator Assembly		X	X		
5	61SA0013A07	Stator Assembly				X	
5	61SA0022A00	Stator Assembly					X
6	61EP3204A01	Bearing Bracket (bearing included with rotor)	X	X	X	X	X
7	EH0320A00	Cover	X	X	X		
7	EH0321A00	Cover				X	
7	EH0322A00	Cover					X

Table A-1 Generator Set Parts List Continued

Ref No.	Part No.	Description	PC30H	PC40H	PC50H	PC60H	PC90VE
10	WD1541A00	Receptacle, 125VAC at 15 Amps	X				
10	WD1541A03	Receptacle, 125VAC at 15 Amps	X				
10	WD1541A33	GFCI Duplex Receptacle, 250VAC at 20 Amps, NEMA 5-20R	X	X	X	X	X
11	WD1541A10	Receptacle, 125VAC at 30 Amps, NEMA L5-30R	X	X	X	X	X
12	WD1541A14	Receptacle, 125/250VAC at 30 Amps, NEMA L14-30R		X	X	X	X
Not Shown	EH0301A00	Control Box (Operator Panel)		X	X	X	
Not Shown	HB6040A01	Control Panel Cover (Operator Panel)		X	X	X	
Not Shown	EH0315A00	Control Box (Operator Panel)					X
Not Shown	EH0330A00	Control Panel Cover (Operator Panel)					X
Not Shown	DI0176A01	Diode	X	X	X	X	X
Not Shown	RR0244A00	Varistor		X	X	X	X
Not Shown	OC3020F12	Capacitor, 20MFD / 370V	X				
Not Shown	OC6030F11	Capacitor, 30MFD / 370V, 90 degree		X	X	X	X
Not Shown	CK0070A01	Circuit Breaker 15Amp		X			
Not Shown	CK0070A03	Circuit Breaker 30Amp	X			X	
Not Shown	CK0070A04	Circuit Breaker 40Amp		X	X		X
Not Shown	CK0070A05	Circuit Breaker 50Amp				X	
Not Shown	CK0070A06	Circuit Breaker 25Amp			X		
Not Shown	TA0002A03	Fuel Cap (with-out Gauge)		X	X	X	X
Not Shown	TA0000A03	Fuel Tank		X	X	X	X
Not Shown	EA0011A00	Fuel Filter, in-line		X	X	X	X
Not Shown	EA0012A21	Fuel Line, 1/4" ID - Filter to Engine		X	X	X	
Not Shown	EA0012A21	Fuel Line, 1/4" ID - Tank to Filter					X
Not Shown	EA0012A22	Fuel Line, 3/16" ID - Tank to Filter		X	X	X	
Not Shown	EA0035A00	Spark Deflector					X
Not Shown	EA0022A01	Spark Arrestor Screen					X
20	BA0188A00L2B	Base Frame		X	X	X	
20	BA0203A00L2B	Base Frame					X
20	BA209A00L2B	Base Frame	X				
21	HB7025A00Z	Engine Mounting Foot		X	X	X	X
22	HB7002A07	Engine end frame cross member		X	X	X	
22	HB7002A08	Engine end frame cross member					X
23	HB6150A01	Alternator end frame cross member		X	X	X	X
Not Shown	RM1088A05	Isolator, Engine end and generator end	X				
Not Shown	RM1088A06	Isolator, Generator end		X	X	X	X
Not Shown	RM1088A07	Isolator, Generator end		X	X	X	X
Not Shown	HB6116A00	Battery Tie Down					X
Not Shown	HA3187A12	Battery Tie Down Bolt					X
Not Shown	LB0094B15	Decal, 120V	X				
Not Shown	LB0094B23	Decal, "Press to Reset"	X				
Not Shown	LB0094A35	Decal, Warning	X	X	X	X	
Not Shown	LB0094A56	Decal,					X
Not Shown	LB0094A92	Decal, PC Series		X	X	X	X
Not Shown	LB9606A02	Decal, Baldor Logo, 6.35"	X	X	X	X	X
Not Shown	LB9606A04	Decal, Baldor Logo, 5.65"		X	X	X	X
Not Shown	LB9606A01	Decal, Baldor Logo, 4"		X	X	X	X
Not Shown	LB9606A05	Decal, Baldor Logo, 7.53"					X
Not Shown	LB9636A00	Decal, PC30H	X				
Not Shown	LB96	Decal, PC40H		X			
Not Shown	LB96	Decal, PC50H			X		
Not Shown	LB96	Decal, PC60H				X	
Not Shown	LB96	Decal, PC90VE					X

Wiring Diagrams Wiring diagrams for these generators are contained on the following pages of this appendix.

Figure A-5 PC30H Wiring Diagram

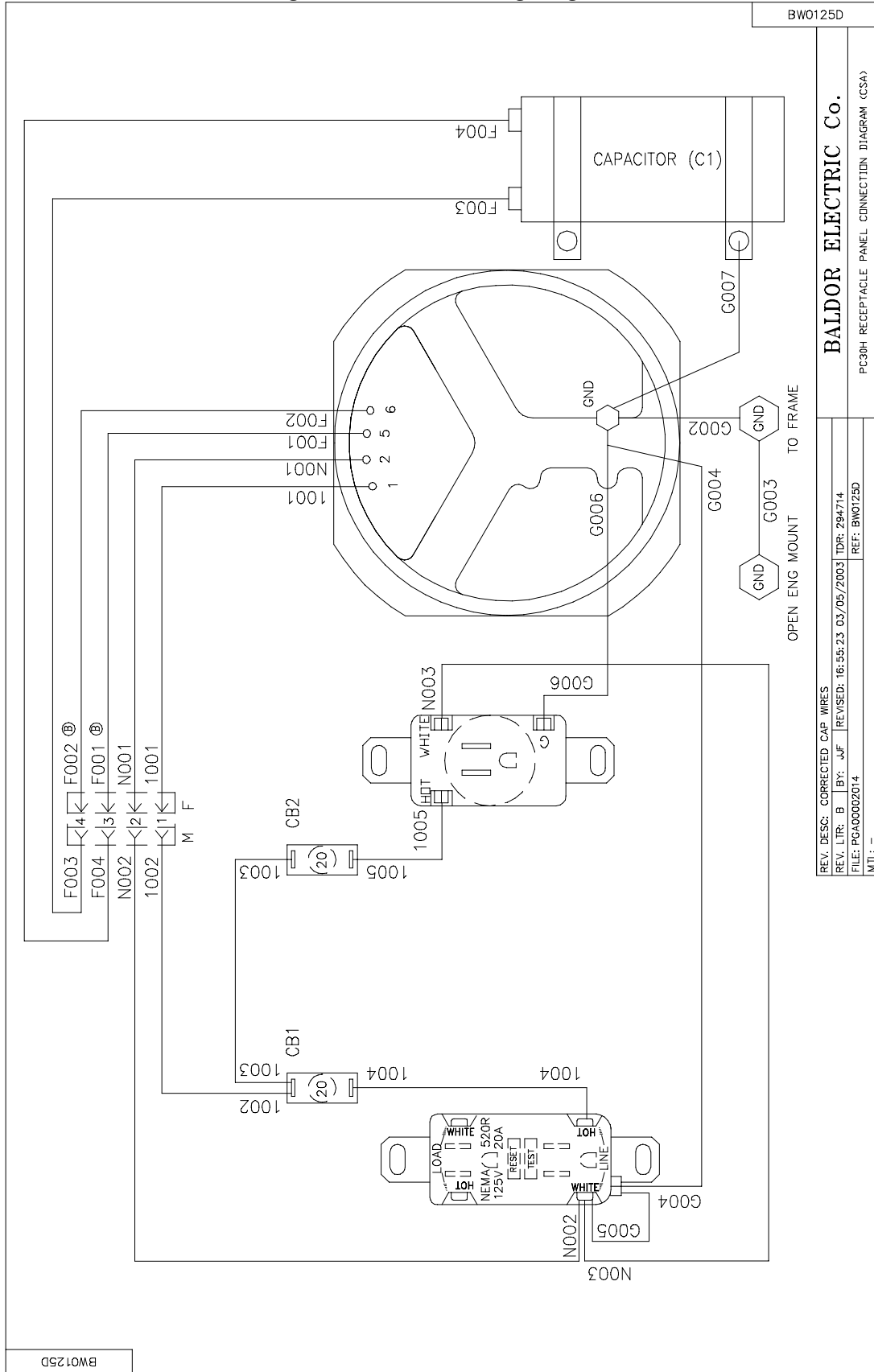

BW0125D

BALDOR ELECTRIC Co.

PC30H RECEPTACLE PANEL CONNECTION DIAGRAM (CSA)

REV. DESC: CORRECTED CAP WIRES	TDR: 294714
REV. LTR: B BY: JF	REVISED: 16/55:23 03/05/2003
FILE: PGA00002014	REF: BW0125D
MTL: --	

BW0125D

Figure A-6 PC40H Wiring Diagram

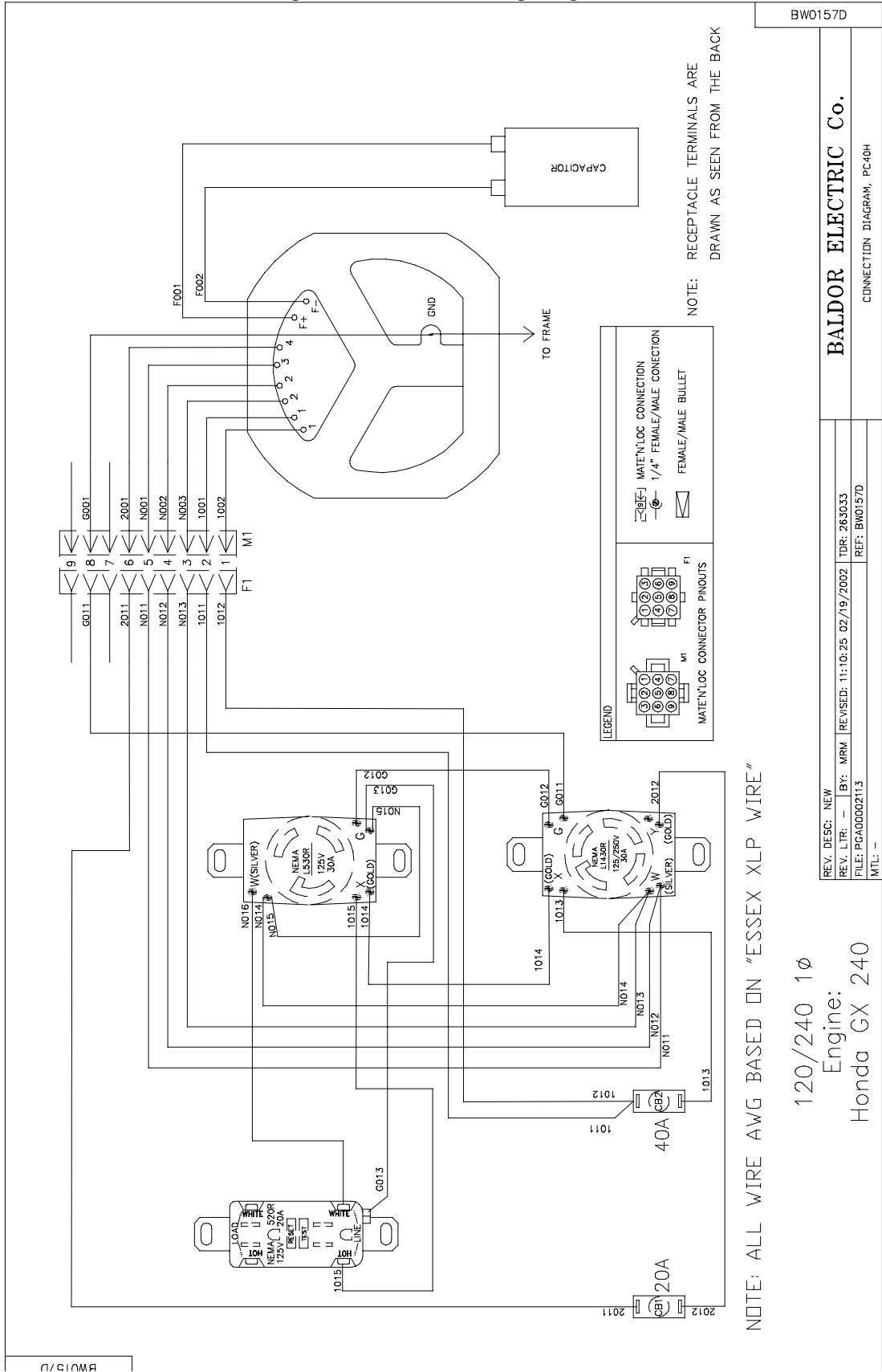

NOTE: ALL WIRE AWG BASED ON "ESSEX XLP WIRE"

120/240 1 ϕ
 Engine:
 Honda GX 240

REV. DESC: NEW	REV. LTR: -	BY: MRM	REVISED: 11:10:25 02/19/2002	TDR: 263033
FILE: PC400002113	REF: BW0157D	CONNECTION DIAGRAM, PC40H		
BALDOR ELECTRIC Co.				
BW0157D				

Figure A-7 PC50H Wiring Diagram

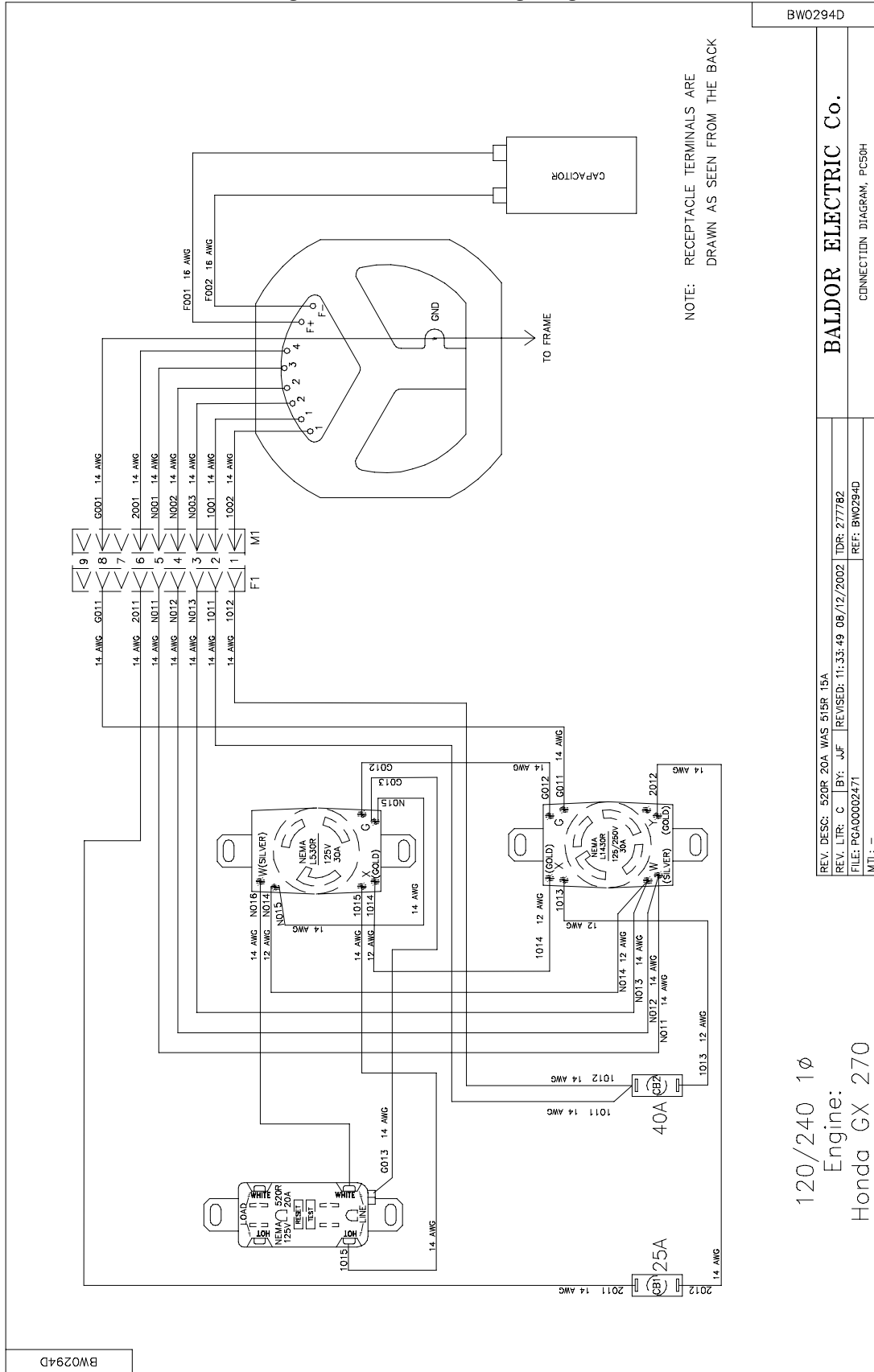

BW0294D

BALDOR ELECTRIC Co.

CONNECTION DIAGRAM, PC50H

REV. DESC: 520R 20A WAS 515R 15A

REV. LTR: C BY: JF REVISED: 11:33:49 08/12/2002 TDR: 277782

FILE: PGA00002471 REF: BW0294D

MFL: -

120/240 1 ϕ
 Engine:
 Honda GX 270

BW0294D

Figure A-8 PC60H Wiring Diagram

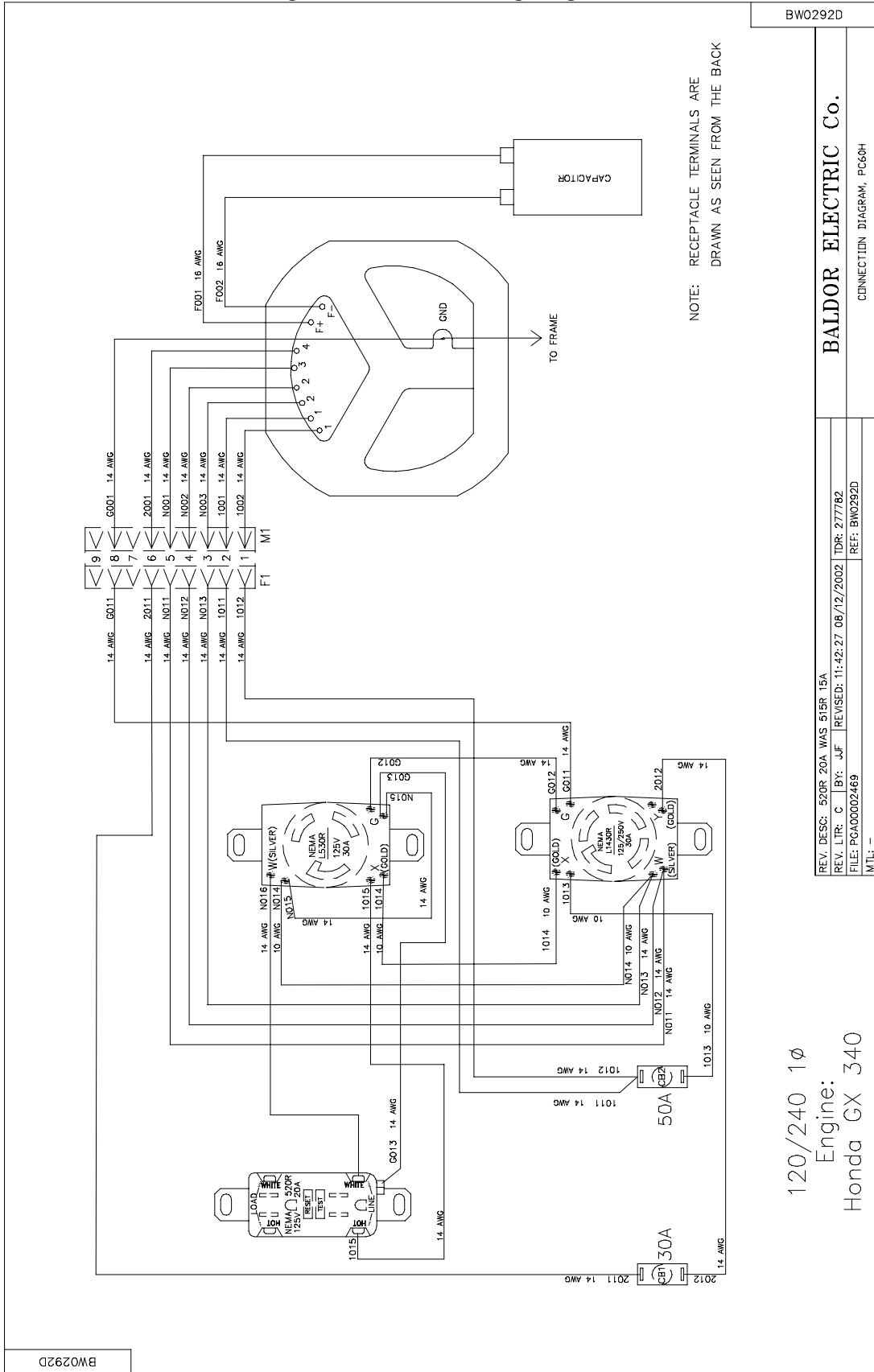

120/240 1 ϕ
 Engine:
 Honda GX 340

NOTE: RECEPTACLE TERMINALS ARE
 DRAWN AS SEEN FROM THE BACK

BW0292D

BALDOR ELECTRIC Co.	
REV. DESC: 520R 20A WAS 515R 15A	REF: BW0292D
REV. LTR: C BY: J-F	TDR: 277782
FILE: PCA00002469	REF: BW0292D
MTL: -	

BW0292D

Figure A-9 PC90VE Wiring Diagram

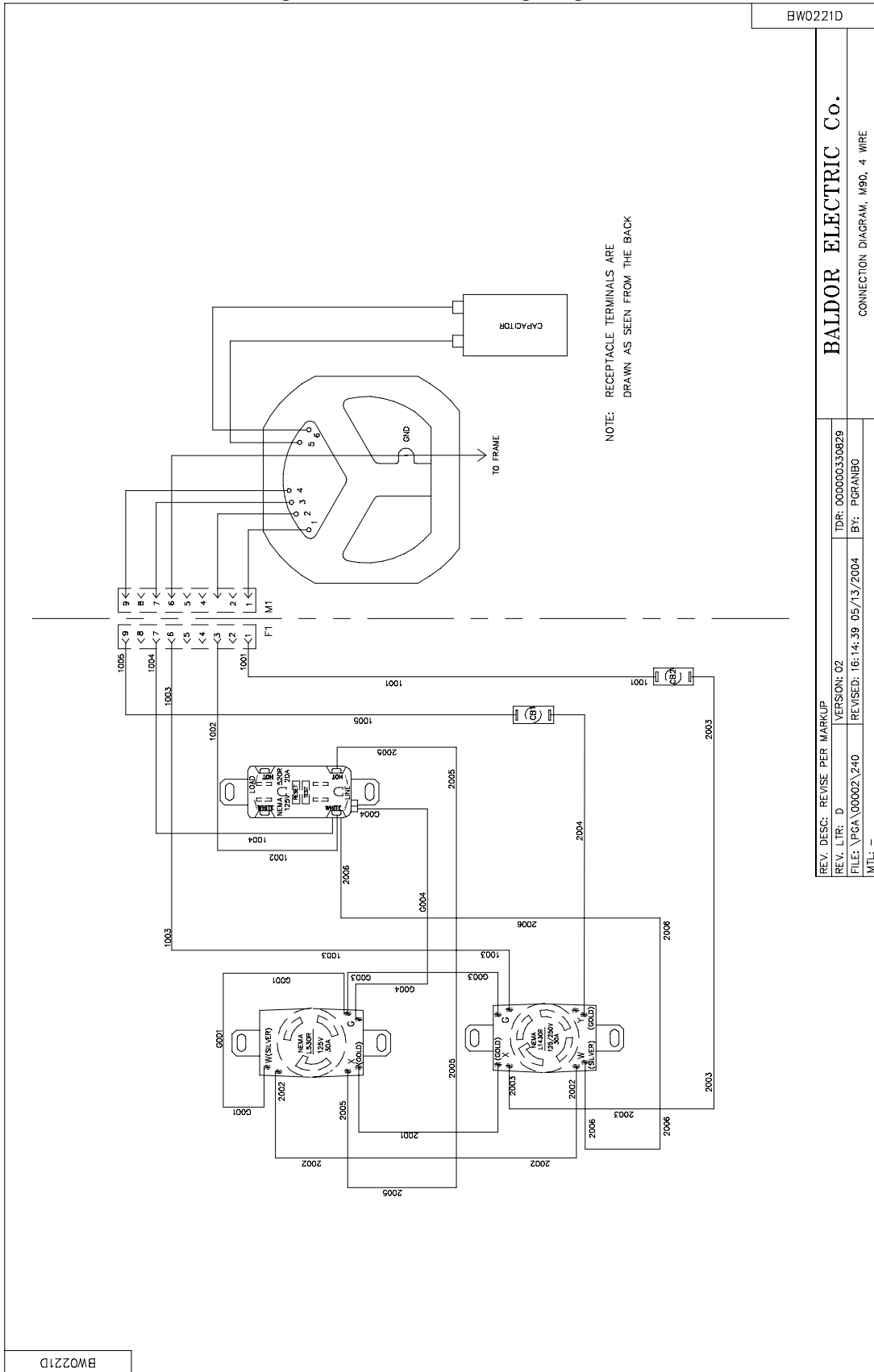

BW0221D

BALDOR ELECTRIC Co.

REV. DESC: REVISE PER MARKUP
 REV. LTR: D
 FILE: \PSA\00002\240
 MTL: --

VERSION: 02
 TDR: 000000330829

BY: PGRANBO

REVISED: 16:14:39 05/13/2004

CONNECTION DIAGRAM, M90, 4 WIRE

BW0221D

Appendix B

Special Information for California

Information in this Appendix applies only to products operated in the state of California.

LIMITED WARRANTY ON EVAPORATIVE EMISSION CONTROL SYSTEMS – CALIFORNIA ONLY

The California Air Resources Board (CARB) and Baldor Generators (herein "Baldor") are pleased to explain the Evaporative Emission Control System (EECS) warranty on your model year 2006 and later generator. In California, new generators must be designed, built and equipped to meet the State's stringent anti-smog standards. Baldor must warrant the EECS on your generator for the period of time listed below provided there has been no abuse, neglect or improper maintenance of your generator. Your EECS may include parts such as the carburetor, fuel-injection system, ignition system, catalytic converter, fuel tanks, fuel lines, fuel caps, valves, canisters, filters, vapor hoses, camps, connectors, and other associated emission-related components. Where a warrantable condition exists, Baldor will repair your generator at no cost to you including diagnosis, parts and labor for the time period set forth below.

BALDOR EVAPORATIVE EMISSION CONTROL SYSTEM DEFECTS WARRANTY COVERAGE

This evaporative emission control system is warranted for a period of two (2) years, subject to the provisions set forth below. If any covered evaporative emission-related part on your equipment is defective, the part will be repaired or replaced by Baldor.

OWNER'S WARRANTY RESPONSIBILITIES

As the generator owner, you are responsible for performance of all the required maintenance listed in your owner's manual. Baldor recommends that you retain all receipts covering maintenance on your generator, but Baldor cannot deny EECS warranty claims solely for the lack of receipts. As the generator owner, you should however be aware that Baldor may deny you warranty coverage if your generator or a part has failed due to abuse, neglect, or improper maintenance or unapproved modifications. You are responsible for presenting your generator to an authorized Baldor service center as soon as the problem exists. The warranty repairs should be completed in a reasonable amount of time, not to exceed 30 days from the date of delivery to the authorized Baldor service center. If you have a question regarding your warranty coverage, you should contact Baldor – Generator Technical Support at 1-479-646-4711.

CONDITIONS AND RESTRICTIONS EVAPORATIVE EMISSIONS CONTROL SYSTEM WARRANTY COVERAGE

Baldor warrants to the ultimate purchaser and each subsequent purchaser that the generator is: (1) designed, built and equipped so as to conform with all applicable CARB EECS regulations; (2) free from defects in materials and workmanship that cause the failure of a warranted part to be identical in all material respects to that part as described in Baldor's application of certification to CARB; (3) the warranty period begins on the date the generator is delivered to an ultimate purchaser or first placed into service. The warranty period is two years.

Subject to certain conditions and exclusions as stated below, the warranty on EVAP emission-related parts is as follows: Any warranted part that is not scheduled for replacement as required maintenance in the written instructions supplied, is warranted for the warranty period. If the part fails during the period of warranty coverage, the part will be repaired or replaced by Baldor at an authorized Baldor service center at no charge to the owner. Any such part repaired or replaced under warranty will be warranted for the remainder of the EECS warranty period. Any warranted part that is scheduled only for regular inspection in the written instructions supplied is warranted for the EECS warranty period. Any such part repaired or replaced under warranty will be warranted for the remaining EECS warranty period. Any warranted part that is scheduled for replacement as required maintenance in the written instructions supplied is warranted for the period of time before the first scheduled replacement date for that part. If the part fails before the first schedule replacement, the part will be repaired or replaced by Baldor. Any such part repaired or replaced under warranty will be warranted for the remainder of the period prior to the first scheduled replacement point for the part. Notwithstanding the provisions herein, EECS warranty services or repairs will be provided at designated service facilities to service the subject equipment. The generator owner will not be charged for diagnostic labor that leads to the determination that an EECS warranted part is defective, if the work is performed at an authorized Baldor service center. Baldor is liable for damages to other Baldor generator equipment components proximately caused by a failure under warranty of any EECS warranted part. Throughout the EECS warranty period, Baldor will maintain a supply of EECS warranted parts sufficient to meet the expected demands for such parts. Any replacement part may be used in the performance of any EECS warranty maintenance or repairs and must be provided without charge to the owner. Such use will not reduce the warranty obligations of Baldor. Add-on or modified parts that are not exempted by the California Air Resources Board may not be used. The use of any non-exempted add-on or modified parts by the ultimate purchaser will be grounds for disallowing warranty claims. Baldor will not be liable to warrant failures of warranted parts caused by the use of a non-exempted add-on or modified part. This limited warranty does not cover any part which malfunctions, fails or is damaged due to failure to follow the maintenance and operating instructions provided with the generator.

EVAPORATIVE EMISSIONS CONTROL SYSTEM WARRANTED PARTS: The repair or replacement of any warranted part otherwise eligible for warranty coverage may be excluded from such warranty coverage if Baldor demonstrates that the generator has been abused, neglected, or improperly maintained, and that such abuse, neglect, or improper maintenance was the direct cause of the need for repair or replacement of the part. That notwithstanding, any adjustment of a component that has a factory installed, and properly operating, adjustment-limiting device is still eligible for warranty coverage. Parts covered under the California Evaporative Emissions Warranty are (1) low permeation fuel lines and fittings.

WARNING:
CALIFORNIA PROPOSITION 65 WARNING:
Engine exhaust from this product contains chemicals known to the state of California to cause cancer, birth defects and other reproductive harm.

WARNING:
CALIFORNIA PROPOSITION 65 WARNING:
Battery posts, terminals and related accessories are known to the state of California to cause cancer, birth defects and other reproductive harm.

Baldor District Offices

UNITED STATES

ARIZONA

PHOENIX
4211 S 43RD PLACE
PHOENIX, AZ 85040
PHONE: 602-470-0407
FAX: 602-470-0464

CALIFORNIA

LOS ANGELES
6480 FLOTILLA
COMMERCE, CA 90040
PHONE: 323-724-6771
FAX: 323-721-5859

HAYWARD
21056 FORBES STREET
HAYWARD, CA 94545
PHONE: 510-785-9900
FAX: 510-785-9910

COLORADO

DENVER
2520 W BARBERRY PLACE
DENVER, CO 80204
PHONE: 303-623-0127
FAX: 303-595-3772

CONNECTICUT

WALLINGFORD
65 SOUTH TURNPIKE ROAD
WALLINGFORD, CT 06492
PHONE: 203-269-1354
FAX: 203-269-5485

FLORIDA

TAMPA/PUERTO RICO/
VIRGIN ISLANDS
3906 EAST 11TH AVENUE
TAMPA, FL 33605
PHONE: 813-248-5078
FAX: 813-247-2984

GEORGIA

ATLANTA
62 TECHNOLOGY DR.
ALPHARETTA, GA 30005
PHONE: 770-772-7000
FAX: 770-772-7200

ILLINOIS

CHICAGO
1601 FRONTENAC ROAD
NAPERVILLE, IL 60563
PHONE: 630-848-5100
FAX: 630-848-5110

INDIANA

INDIANAPOLIS
5525 W. MINNESOTA STREET
INDIANAPOLIS, IN 46241
PHONE: 317-246-5100
FAX: 317-246-5110
800-428-4141

IOWA

DES MOINES
1800 DIXON STREET, SUITE C
DES MOINES, IA 50316
PHONE: 515-263-6929
FAX: 515-263-6515

MARYLAND

BALTIMORE
6660 SANTA BARBARA RD.
SUITE 22-24
ELKRIDGE, MD 21075
PHONE: 410-579-2135
FAX: 410-579-2677

MASSACHUSETTS

BOSTON
6 PULLMAN STREET
WORCESTER, MA 01606
PHONE: 508-854-0708
FAX: 508-854-0291

MICHIGAN

DETROIT
33782 STERLING PONDS BLVD.
STERLING HEIGHTS, MI 48312
PHONE: 586-978-9800

FAX: 586-978-9969

MICHIGAN Continued

GAND RAPIDS
668 3 MILE ROAD NW
GRAND RAPIDS, MI 49504
PHONE: 616-785-1784
FAX: 616-785-1788

MINNESOTA

MINNEAPOLIS
21080 134TH AVE. NORTH
ROGERS, MN 55374
PHONE: 763-428-3633
FAX: 763-428-4551

MISSOURI

ST LOUIS
422 INDUSTRIAL DRIVE
MARYLAND HEIGHTS, MO 63043
PHONE: 314-298-1800
FAX: 314-298-7660

KANSAS CITY

915 N W PLATTE VALLEY DR
RIVERSIDE, MO 64150
PHONE: 816-587-0272
FAX: 816-587-3735

NEW YORK

AUBURN
ONE ELLIS DRIVE
AUBURN, NY 13021
PHONE: 315-255-3403
FAX: 315-253-9923

NORTH CAROLINA

GREENSBORO
1220 ROTHERWOOD ROAD
GREENSBORO, NC 27406
P O BOX 16500
GREENSBORO, NC 27416
PHONE: 336-272-6104
FAX: 336-273-6628

OHIO

CINCINNATI
2929 CRESCENTVILLE ROAD
WEST CHESTER, OH 45069
PHONE: 513-771-2600
FAX: 513-772-2219

CLEVELAND

8929 FREEWAY DRIVE
MACEDONIA, OH 44056
PHONE: 330-468-4777
FAX: 330-468-4778

OKLAHOMA

TULSA
2 EAST DAWES
BIXBY, OK 74008
PHONE: 918-366-9320
FAX: 918-366-9338

OREGON

PORTLAND
20393 SW AVERY COURT
TUALATIN, OR 97062
PHONE: 503-691-9010
FAX: 503-691-9012

PENNSYLVANIA

PHILADELPHIA
1035 THOMAS BUSCH
MEMORIAL HIGHWAY
PENNSAUKEN, NJ 08110
PHONE: 856-661-1442
FAX: 856-663-6363

PITTSBURGH

616H BEATTY ROAD
MONROEVILLE, PA 15146
PHONE: 412-380-7244
FAX: 412-380-7250

TENNESSEE

MEMPHIS
4000 WINCHESTER ROAD
MEMPHIS, TN 38118
PHONE: 901-365-2020
FAX: 901-365-3914

TEXAS

HOUSTON
4647 PINE TIMBERS
SUITE # 135
HOUSTON, TX 77041
PHONE: 713-895-7062
FAX: 713-690-4540

DALLAS

3040 QUEBEC
DALLAS, TX 75247
PHONE: 214-634-7271
FAX: 214-634-8874

UTAH

SALT LAKE CITY
2230 SOUTH MAIN STREET
SALT LAKE CITY, UT 84115
PHONE: 801-832-0127
FAX: 801-832-8911

WISCONSIN

MILWAUKEE
2725 SOUTH 163RD STREET
NEW BERLIN, WI 53151
PHONE: 262-784-5940
FAX: 262-784-1215

INTERNATIONAL SALES

FORT SMITH, AR
P.O. BOX 2400
FORT SMITH, AR 72902
PHONE: 479-646-4711
FAX: 479-648-5895

CANADA

EDMONTON, ALBERTA
4053-92 STREET
EDMONTON, ALBERTA T6E 6R8
PHONE: 780-434-4900
FAX: 780-438-2600

OAKVILLE, ONTARIO

2750 COVENTRY ROAD
OAKVILLE, ONTARIO L6H 6R1
PHONE: 905-829-3301
FAX: 905-829-3302

MONTREAL, QUEBEC

1844 WILLIAM STREET
MONTREAL, QUEBEC H3J 1R5
PHONE: 514-933-2711
FAX: 514-933-8639

VANCOUVER,

BRITISH COLUMBIA
1538 KEBET WAY
PORT COQUITLAM, BC V3C 5M5
PHONE: 604-421-2822
FAX: 604-421-3113

WINNIPEG, MANITOBA

54 PRINCESS STREET
WINNIPEG, MANITOBA R3B 1K2
PHONE: 204-942-5205
FAX: 204-956-4251

AUSTRALIA

UNIT 3, 6 STANTON ROAD
SEVEN HILLS, NSW 2147,
AUSTRALIA
PHONE: (61) (2) 9674 5455
FAX: (61) (2) 9674 2495

UNIT 8, 5 KELLETTS ROAD

ROWVILLE, VICTORIA, 3178
AUSTRALIA
PHONE: (61) (3) 9753 4355
FAX: (61) (3) 9753 4366

BALDOR CENTROAMERICA

RESIDENCIAL PINARES DE SUIZA
POL. 15 #44, NVA. SAN SALVADOR
EL SALVADOR, CENTRO AMERICA
PHONE: (503) 288-1519
FAX: (503) 288-1518

BALDOR SUDAMERICA

CALLE F, EL CANGREJO
CONDominio P.H. CONDADO PLAZA
APT. 11D, BELLA VISTA
PANAMÁ CITY, REP. DE PANAMÁ
PHONE: (507) 265-6041

CHINA

SHANGHAI JIAHUA BUSINESS CENTER
ROOM NO. A-8421
808 HONG QIAO ROAD
SHANGHAI 200030
PHONE: 86-21-64473060
FAX: 86-21-64078620

GERMANY

DIESELSTRASSE 22
D-85551 KIRCHHEIM
MUNICH, GERMANY
PHONE: (49) (89) 90508 - 0
FAX: (49) (89) 90508 - 492

INDIA

14, COMMERCE AVENUE
MAHAGANESH COLONY
PAUD ROAD
PUNE - 411 038
MAHARASHTRA, INDIA
PHONE: 91 20 25 45 95 31/32
FAX: 91 20 24 55 95 30

ITALY

BALDOR ASR AG
SUCCURSALE DI MENDRISIO
VIA BORROMINI, 20A
CH-6850 MENDRISIO
SWITZERLAND
PHONE: 41 91 640 9952
FAX: 41 91 630 2633

JAPAN

DIA BLDG 802,
2-21-1 TSURUYA-CHO,
KANAGAWA-KU
YOKOHAMA, 221-0835, JAPAN
PHONE: 81-45-412-4506
FAX: 81-45-412-4507

KOREA

ROOM 210
BUPYEONG INDUSTRIAL
COMMERCIAL COOPERATIVE
396-16 CHEONGCHEON 2-DONG,
BUPYEONG-GU
INCHEON, KOREA, 403-858
PHONE: 82 32 508 3252
FAX: 82 32 508 3253

MÉXICO

KM. 2.0 BLVD. AL AEROPUERTO
LEÓN 37545, GUANAJUATO, MÉXICO
PHONE: 52 477 761 2030
FAX: 52 477 761 2010

MIDDLE EAST & NORTH AFRICA

VSE INTERNATIONAL CORP.
3233 NORTH ARLINGTON HEIGHTS
SUITE 100W
ARLINGTON HEIGHTS, IL 60004
PHONE: 847 590 5547

SINGAPORE

51 KAKI BUKIT ROAD 2
K B WAREHOUSE COMPLEX
SINGAPORE 417863
PHONE: (65) 6 744 2572
FAX: (65) 6 747 1708

SWITZERLAND

POSTFACH 73
SCHUTZENSTRASSE 59
CH-8245 FEUERTHALEN
SWITZERLAND
PHONE: (41) (52) 6474700
FAX: (41) (52) 6592394

TAIWAN

4F, NO. 25, SEC. 1,
TUNHUA S ROAD,
TAIPEI 10557, TAIWAN, R.O.C.
PHONE: (886-2) 2577-4352
FAX: (886-2) 2577-4157

UNITED KINGDOM

6 BRISTOL DISTRIBUTION PARK
HAWKLEY DRIVE
BRISTOL BS32 0BF U.K.
PHONE: 44 1454 850000
FAX: 44 1454 859001

**WARNING:
CALIFORNIA PROPOSITION 65 WARNING:**

Engine exhaust from this product contains chemicals known to the state of California to cause cancer, birth defects and other reproductive harm.

**WARNING:
CALIFORNIA PROPOSITION 65 WARNING:**

Battery posts, terminals and related accessories are known to the state of California to cause cancer, birth defects and other reproductive harm.



**BALDOR ELECTRIC COMPANY
P.O. Box 2400
Ft. Smith, AR 72902-2400
(479) 646-4711
Fax (479) 648-5792**

CH TEL: +41 52 647 4700 FAX: +41 52 659 2394	D TEL: +49 89 90 50 80 FAX: +49 89 90 50 8491	UK TEL: +44 1454 850000 FAX: +44 1454 850001	F TEL: +33 145 10 7902 FAX: +33 145 09 0864
I TEL: +39 11 562 4440 FAX: +39 11 562 5660	AU TEL: +61 29674 5455 FAX: +61 29674 2495	CC TEL: +65 744 2572 FAX: +65 747 1708	MX TEL: +52 477 761 2030 FAX: +52 477 761 2010

