

Standby or Prime Power Features

- Heavy-duty gaseous GM industrial engine
- Brushless synchronous alternators: four-pole construction, dynamically balanced
- Full featured microprocessor based controller: fully programmable for maximum flexibility
- Prototype tested and production tested
- Gen-set accepts rated load in one step
- UL2200 available – consult factory
- Optional weather-proof and sound attenuated enclosures available
- Full range of accessories and options available
- Heavy-duty construction for use in prime or standby application
- Manufactured in an ISO-9001 certified facility
- Backed by a world wide network of parts and service centers

Gen Set Ratings

Model GLC50				Natural Gas				LP Gas				
				150°C Rise Standby Rating		105°C Rise Prime Rating		150°C Rise Standby Rating		105°C Rise Prime Rating		
Generator	Voltage	Phase	Hz	kW/kVA	Amps	kW/kVA	Amps	kW/kVA	Amps	kW/kVA	Amps	
UCI224D	120/208	3	60	50/62	173	42/52	146	50/62	173	42/52	146	
	127/220	3	60	50/62	164	44/55	144	50/62	164	44/55	144	
	120/240	3	60	50/62	150	42/52	126	50/62	150	42/52	126	
	139/240	3	60	60	50/62	150	45/56	135	50/62	150	45/56	135
	220/380	3	60	60	45/56	85	38/47	58	45/56	85	38/47	58
	277/480	3	60	60	50/62	75	45/56	68	50/62	75	45/56	68
UC1224D	120/240	1	60	50/50	417/208	40/40	333/167	50/50	417/208	40/40	333/167	

IMPORTANT NOTES:

- For ratings and voltages not listed above consult Factory
- Standby ratings do not have an overload capability but can be used for the duration of the utility failure per ISO-3046, DIN6271 and BS5514
- Prime (Unlimited Running Time) ratings are continuous per DIN 6271 and ISO-3046 with 10% overload capacity
- Base Load (Continuous) ratings are continuous per DIN 6271, BS5514 and ISO-8528 with no sustained overload capacity. Consult factory for Base Load ratings.
- Altitude derate is 4% for each 1000 feet over 5000
- Temperature derate is 1% for 10°F over 100°F ambient

Controls Digital Control Module

Controller

- Microprocessor-based circuitry
- Standard features meet requirements of NFPA110 Level 1
- Backlit LCD display
- Digital 3-phase voltage, current & frequency metering
- Up to 28 alarm/shutdown fault circuits analog/digital inputs
- EMI/RFI noise immunity per IEEE C62.41
- Certified to UL #508

Standard Features

- Timers – Engine start, Cooldown, Oil Bypass, Cycle crank
- Control switches – Run/Auto/Load test, horn test, Lamp test, Common
- LCD Display menu – AC metering, timer, Alarm/shutdown, engine
- Diagnostic LED indicators – Watchdog (CPU running), run output energized, remote start signal initiated, common fail output energized

- Fully configurable from front panel keypad
- Password protected
- Low Oil Pressure Alarm Light
- High Coolant Temperature Alarm Light
- Overspeed Alarm Light

Shutdowns

- Overspeed
- Over-crank
- Loss of speed signal
- High engine temperature
- Low Oil Pressure Shutdown
- Emergency stop

Engine Technical Data

Manufacturer	General Motors
Engine Model & Type	Vortec, 4 cycle, Natural Aspiration
Cylinder Configuration	V-8
Displacement - cu. in.(Liters)	350 (5.7)
Bore and Stroke - in. - mm	4.00 x 3.48 (101.6 x 88.4)
Compression ratio	9.1:1
Water pump type	Centrifugal
Piston speed, M/sec. (ft./min)	5.30 (1044)
Rated rpm	1800
Max. power at rated rpm, kW (Hp)	78.3 (105)
Fuel type	LP Gas or Natural Gas
Governor type	Electronic
Governor make	Woodward
Frequency regulation, steady state	+/- 0.5%
Frequency regulation, no load to full load	Isochronous
Air filter type	Dry
Oil pan capacity qt (L)	5.0 (4.7)
Oil pan capacity w/filter – qt – liters	6.2 (6.5)
Oil Filter: quantity, type	1, Cartridge
Rec'd oil type - SF/CC/CD-10°F to 90°F	5W-30
Battery charging alternator:	
- Ground (negative/positive)	Negative
- Volts (DC)	12
- Ampere rating	70
Battery voltage	12VDC

Gen Set Technical Data

Alternator Technical Data

Generator Frame	224	Voltage Regulation NL - FL	+/- 1.5%
Exciter	Brushless	Underspeed Protection	Standard
Cooling Fan	Cast alloy aluminum	Overexcitation Protection	Standard
Bearing	Single, double shielded	Overvoltage Protection	Optional
Connection Type	Reconnectable	Loss of Sensing Protection	Standard
Insulation Type	Class H	Overspeed	2250 RPM
Windings	100% copper	Standards	NEMA, IEC, IEEE, CSA, BS
Pitch	2/3	Phase Sequence	A(U),B(V),C(W)
Amortisseur Winding	Full	TIF (1960 Weightings)	<50
Voltage Regulator	SX460	Excitation System	PMG - optional
SKVA output with 30% voltage dip max. 480V @ 60 Hz = 155			

Fuel System Requirements

Fuel Type	LP Gas or Natural Gas
Fuel supply line inlet	1" NPTF
Natural gas/LpG fuel supply pressure, oz./in. ² (in H ₂ O)	4-6 (7.0-11.0)

NOTE: Ratings based on 60 Hz

Exhaust System Requirements

Exhaust flow at rated kW, m ³ /min. (cfm)	15.6 (550)
Exhaust temperature at rated kW, dry exhaust, °C (°F)	593 (1100)
Maximum allowable back pressure, kPa (in. Hg)	10.2 (3.0)
Exhaust outlet size at engine hookup, mm (in.)	76 (3.0)

Fuel Consumption	Natural Gas, m ³ /hr. (cfh) at % Load		LP Gas, m ³ /hr. (cfh) at % Load	
	Standby Rating @ 60 Hz	Prime Rating @ 60 Hz	Standby Rating @ 60 Hz	Prime Rating @ 60 Hz
100%	20.7 (731)	19.4 (685)	82. (289)	7.4 (261)
75%	17.5 (618)	16.3 (575)	6.2 (218)	5.9 (208)
50%	13.4 (473)	12.5 (441)	4.7 (165)	4.6 (162)
25%	9.1 (321)	8.9 (314)	3.4 (120)	3.3 (116)

Cooling (Standard Radiator)

Ambient temperature, °C (°F)	50 (122)
Engine jacket water capacity, L (gal.)	6.8 (1.8)
Radiator system capacity, including engine, L (gal.)	24.6 (6.5)
Engine jacket water flow, Lpm (gpm)	117.3 (33)
Heat rejected to cooling water at rated kW, dry exhaust, kW (Btu/min.)	54.8 (3120)
Water pump type	Centrifugal
Fan diameter including blades, mm (in.)	533.4 (21)
Fan, kWm (Hp)	4.5 (6.0)
Max. restriction of cooling air, intake and discharge side of radiator, Kpa (in. H ₂ O)	0.125 (.5)

Engine Operational Values

Air Requirements	60 Hz
Radiator-cooled cooling air – m ³ /min. (scfm)	238 (8400)
Combustion air required – m ³ /min. (cfm)	5.0 (175)
Heat rejected to ambient, engine – Btu/min (kW)	1680 (29.5)
Heat rejected to ambient, generator – Btu/min (kW)	430 (7.6)

NOTE: Power corrected for ambient conditions per engine manufacturer's recommendations.

Accessories and Options

Control Panel

- High Coolant Temp. Pre-alarm
- Low Oil Pressure Pre-alarm
- Alarm Horn with Switch
- Remote Start-Stop
- Remote Annunciator

PER NFPA 110

- Run Relay
- Dry Contacts

Engine Exhaust System

- Industrial Silencer
- Residential Silencer
- Critical Silencer
- Exhaust Flex
- Rain Cap
- _____

Generator Accessories

- Main Line Circuit Breaker
- Shunt Trip
- Alternator Heater
- Field Circuit Breaker
- PMG
- _____

Engine Electrical System

- Batteries
- Battery Rack
- Battery Cables
- Battery Charger - Automatic
- Battery Charger - Trickle
- _____

Engine Fuel System

- Flexible Fuel Lines
- _____

Miscellaneous

- Weather protective Enclosure
- Sound Attenuated Enclosure
- Vibration Isolators
- Coolant Heater
- _____

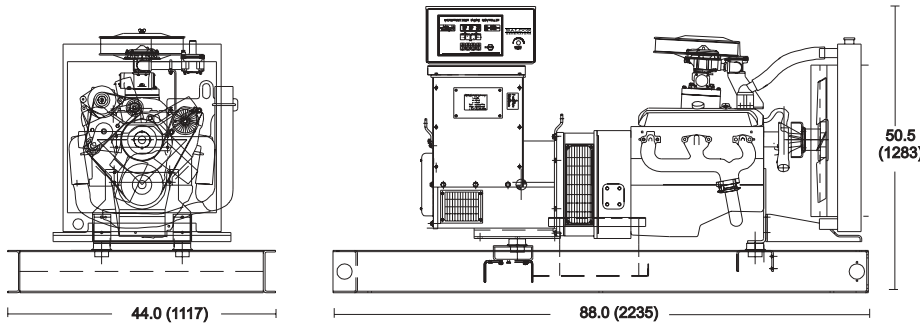

Dimensions – in (mm)

Weight – lbs. (Kg)
3500 (1590)

Cubes (Approximate)
135 ft

*Open unit configuration,
accessories not included

Ratings – Standby Ratings: Standby ratings are applicable for supplying emergency power for the duration of a utility power outage. Primary power to the installation is utility supplied. No overload capability for standby rating. Standby ratings in accordance with ISO 3046, BS55114, DIN 6271. **Continuous Power Rating:** Continuous power is the maximum power available for continuous duty. A 10% overload capacity is available for 1 hour out of 12 hours of operation. Prime Power ratings in accordance with ISO 3046, BS55114, DIN 6271. For additional information, please consult factory. Manufacture reserves the right to implement specifications or design changes without notice.

Distributed by:

BALDOR
GENERATORS

3815 Oregon Street • Oshkosh, WI 54902 • 1-800-872-7697 • Phone (920) 236-4200 • Fax (920) 236-4219
909 Perkins Drive • Mukwonago, WI 53149 • Phone (262) 363-1555 • Fax (262) 363-1556

World Headquarters

Baldor Electric Company • P.O. Box 2400 • Fort Smith, AR 72902-2400 U.S.A.
Phone (479) 646-4711 • Fax (479) 648-5792 • International Fax (479) 648-5895

www.baldor.com