

## Standby or Prime Power Features

- Heavy-duty Cummins 4-stroke gas engine, water-cooled
- Brushless synchronous alternators: four-pole construction, dynamically balanced
- Full featured microprocessor based controller: fully programmable for maximum flexibility
- Prototype tested and production tested
- UL2200 available – consult factory
- Optional weather-proof and sound attenuated enclosures available
- Full range of accessories and options available
- Heavy-duty construction for use in prime or standby application
- Manufactured in an ISO-9001 certified facility
- Backed by a world wide network of parts and service centers

## Gen Set Ratings

Baldor Genset Model	kW Rating Standby	kW Rating Prime	kW Rating Standby	kW Rating Prime	Voltage Hi-Wye	Voltage Low-Wye	Voltage Delta	Number of Leads	Phase	Hz	Power Factor
	Natural Gas 12:1		LP Gas 10:1								
IGLC145N/L-CA	145	130	135	125	480/277	240/139	N/A	12	3	60	0.8
IGLC145N/L-CA	145	130	135	125	440/254	220/127	N/A	12	3	60	0.8
IGLC145N/L-CA	145	130	135	125	416/240	208/120	240/120	12	3	60	0.8
IGLC145N/L-CB	145	130	135	125	380/220	N/A	N/A	12	3	60	0.8
IGLC145N/L-CE	145	130	135	125	N/A	N/A	240/120	4	1	60	1.0
IGLC145N/L-CH	145	130	135	125	600/347	N/A	N/A	12	3	60	0.8
IGLC145N/L-CXA	125	110	115	105	380/220	N/A	220/110	12	3	50	0.8

**NOTES:** For ratings and voltages not listed above refer to the Gen-Set Selector or consult factory  
 Standby ratings do not have an overload capability but can be used for the duration of the utility failure per ISO-3046, DIN6271 and BS5514  
 Prime (Unlimited Running Time) ratings are continuous per DIN 6271 and ISO-3046 with 10% overload capacity  
 Base Load (Continuous) ratings are continuous per DIN 6271, BS5514 and ISO-8528 with no sustained overload capacity  
 Consult factory for Base Load ratings  
 Altitude derate is 4% for each 1000 feet over 3000  
 Temperature derate is 1% for 10°F over 100°F ambient

# Controls Digital Control Module

## MEC2 Features

- Large Backlit LCD with alpha-numeric readout
- Microprocessor Based Design
- 16 programmable alarms/shutdowns set points
- 4 programmable inputs
- Alarm horn
- Not in Automatic Alarm
- Digital Three Phase Voltage and Current Monitoring
- Password Protected Front Panel Programming
- 4 Programmable Outputs
- Local Emergency Stop Switch
- Optional NFPA110 Level I

## Engine Protections

- Digital Oil Pressure Gauge
- Digital Water Temperature Gauge
- Digital Battery Voltmeter
- Overspeed Shutdown
- Emergency Stop Shutdown
- Loss of Speed Signal
- Overcrank Shutdown

## Designed To Meet/Exceed the Standards Below:

- UL 508
- UL 2200
- NFPA 70
- NFPA 110

## Engine Technical Data

Manufacturer	Cummins
Engine Model	G855
Engine Type	4 cycle, 6 cylinders
Aspiration	Naturally Aspirated
Configuration	In-line
Displacement - cu. in. (liters)	855 (14.0)
Bore and Stroke - in. (mm)	5.5 x 6.0 (130 x 152)
Compression Ratio	12:1 (10:1)
Air Filter Type	Dry
Governor Type	Electronic
Governor Model	Woodward Flowtech
Injection Pump Type/Model	75 mm
Frequency Regulation, steady state	+/- 0.25%
Frequency Regulation, no load to full load	Isochronous
Battery Voltage	24 VDC
Water Pump Type	Centrifugal
Coolant Cap. - radiator cooled - gals - liters	27 (25.5)
Coolant Capacity - engine only - gals - liters	22 (21)
Oil Pan Capacity - gals - liters	34.1-26.5 9.0-7.0
Rec'd Oil Type - SF/CC/CD-10°F to 90°F	10W-40

Engine Operational Values	English 50 Hz	Metric 50 Hz	English 60 Hz	Metric 60 Hz
Maximum ambient temperature - F° - C°	100	38	100	38
Heat rejected to coolant - Btu/min - kW	7,370	129	8,736	153
Heat rejected to aftercooler - Btu/min - kW	N/A	N/A	N/A	N/A
Max. power at rated rpm - bhp - kWm	184	137	220	164
Coolant flow - gpm - lpm	93	352	113	428
Exhaust temperature - F° - C° (maximum)	1,350	732	1,350	732
Exhaust flow - cfm - m <sub>3</sub> /min	927	438	1,111	524
Gas pressure required - in. H <sub>2</sub> O - mm H <sub>2</sub> O	10 -20	254 - 508	10 -20	254 - 508
Minimum pipe size @ engine - in. - mm	2	51	2	51
Normal oil pressure high - PSI - kPa	50-70	345-483	50-70	345-483

# Gen Set Technical Data

## Alternator Technical Data

Generator Frame	274	Voltage Regulation NL - FL	1.50%
Exciter	Brushless	Underspeed Protection	Standard
Cooling Fan	Cast alloy aluminum	Overexcitation Protection	Optional
Bearing	Single, double shielded	Overvoltage Protection	Optional
Connection Type	Reconnectable	Loss of Sensing Protection	Standard
Insulation Type	Class H	Overspeed	2250 RPM
Windings	100% copper	Standards	NEMA, IEC, IEEE, CSA, BS
Pitch	2/3	Phase Sequence	A(U), B(V), C(W)
Amortisseur Winding	Full	TIF (1960 Weightings)	<50
Voltage Regulator	SX460	Excitation System	Shunt – PMG Optional

## Alternator Performance Data

	Model IGLC145N/L-CA	Model IGLC145N/L-CB	Model IGLC145N/L-CD	Model IGLC145N/L-CH
Temperature rise by resistance - °C (Stand-By)	150/40	150/40	150/40	150/40
Generator model number	UCI274F	UCI274G	UCD274J	UCI274F
Generator kW at 130/105/80°C over 40°C amb. (480 Volt , 60Hz)	165/150/128	180/165/140	240/220/194	165/150/128
SKVA output with 30% voltage dip max. 100% recovery at 60 Hz	420	510	680	420
Maximum skva at 90% sustained voltage dip	Consult Factory	Consult Factory	Consult Factory	Consult Factory
Subtransient reactance at voltage listed	12.00%	12.00%	8.00%	12.00%
Line - line harmonic maximum total	3.50%	3.50%	3.50%	3.50%

## Installation/Application Data

	English 50 Hz	Metric 50 Hz	English 60 Hz	Metric 60 Hz
<b>Ventilation requirements</b>				
a. Cooling airflow required - cfm - l/s (unit mounted radiator)	10,000	4,720	14,000	6,608
b. Combustion air required - cfm - l/s	315	149	379	179
Total ventilation requirements - cfm - l/s (a. + b.)	10,315	4,869	14,379	6,787
Maximum cooling air restriction - in.H <sub>2</sub> O - mm.H <sub>2</sub> O	0.5	13	0.5	13
Minimum intake louver size (based on "free area") ft <sup>2</sup> - m <sup>2</sup>	14	1.3	14	1.3
a. Heat rejected to ambient, engine - Btu/min - kW	1,798	32	1,798	32
b. Heat rejected to ambient, generator - Btu/min - kW	781	14	934	16
Total heat rejection to ambient - Btu/min - kW (a. + b.)	2,579	45	2,732	48

## Exhaust system requirements

Exhaust gas flow - cfm - m <sup>3</sup> /min	927	438	1,111	524
Exhaust temperature (dry manifold) - °F - °C	1,350	732	1350	732
Maximum back pressure - in.hg - mm.hg (inclusive of silencer)	2	50.8	2	50.8
Exhaust outlet size - in. - mm	4	101.6	4	101.6
Emissions - HC - g/hp-hr	Consult Factory		Consult Factory	
Emissions - CO - g/hp-hr	Consult Factory		Consult Factory	
Emissions - NOX - g/hp-hr	Consult Factory		Consult Factory	

## Fuel system requirements – see engine operational values for gas pressure requirements

Fuel consumption - 1/4 load - cu.ft/hr - BTU/Hp-hr (natural gas)	959	755	652	513
Fuel consumption - 1/2 load - cu.ft/hr - BTU/Hp-hr (natural gas)	1,116	878	1,195	940
Fuel consumption - 3/4 load - cu.ft/hr - BTU/Hp-hr (natural gas)	1,297	1,021	1,557	1,225
Fuel consumption - Full load - cu.ft/hr - BTU/Hp-hr (natural gas)	1,508	1,187	1,810	1,424

Conversions: Cubic feet of Natural Gas/2.644 = Cubic Feet of LPG and Cubic Feet of LPG/8.533 = Gallons of LPG per hour - "estimated"

## Heat Exchanger Cooling system requirements

Minimum raw water (city water) flow - gpm/lps	Consult Factory	Consult Factory	Consult Factory	Consult Factory
Maximum supply water temperature - °F - °C	80°F	12.44°C	80°F	12.44°C

## Remote Cooling system requirements

Maximum coolant static head - ft. - m	46	14	46	14
Ventilation required (based on 25°F temp rise) - cfm - lps	5,732	101	6,071	107

# Accessories and Options

## Control Panel

- High Coolant Temp. Pre-alarm
- Low Oil Pressure Pre-alarm
- Alarm Horn with Switch
- Remote Start-Stop
- Remote Annunciator

PER NFPA 110

- Run Relay
- Dry Contacts

## Engine Exhaust System

- Industrial Silencer
- Residential Silencer
- Critical Silencer
- Exhaust Flex
- Rain Cap
- \_\_\_\_\_

## Generator Accessories

- Main Line Circuit Breaker
- Shunt Trip
- Alternator Heater
- Field Circuit Breaker
- PMG
- \_\_\_\_\_

## Engine Electrical System

- Batteries
- Battery Rack
- Battery Cables
- Battery Charger - Automatic
- Battery Charger - Trickle
- \_\_\_\_\_

## Engine Fuel System

- Flexible Fuel Lines
- \_\_\_\_\_

## Miscellaneous

- Weather protective Enclosure
- Sound Attenuated Enclosure
- Vibration Isolators
- Coolant Heater
- \_\_\_\_\_

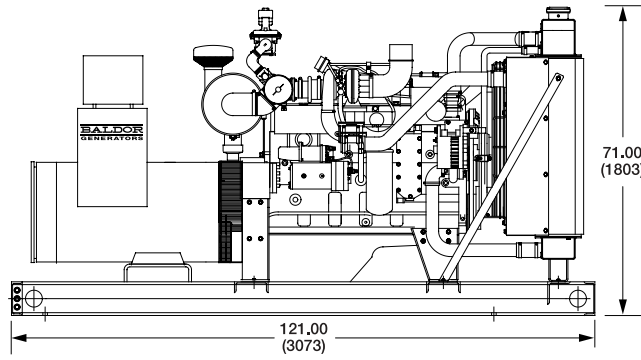
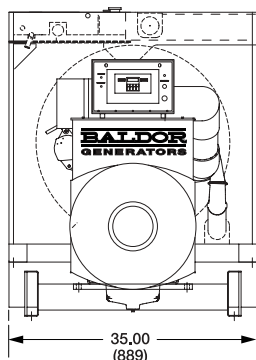

Dimensions – in (mm)

Weight – lbs. (Kg)  
5240 (2377)

Cubes (Approximate)  
173 ft

\*Open unit configuration,  
accessories not included

**Ratings – Standby Ratings:** Standby ratings are applicable for supplying emergency power for the duration of a utility power outage. Primary power to the installation is utility supplied. No overload capability for standby rating. Standby ratings in accordance with ISO 3046, BS55114, DIN 6271. **Continuous Power Rating:** Continuous power is the maximum power available for continuous duty. A 10% overload capacity is available for 1 hour out of 12 hours of operation. Prime Power ratings in accordance with ISO 3046, BS55114, DIN 6271. For additional information, please consult factory. Manufacture reserves the right to implement specifications or design changes without notice.

*Distributed by:*



3815 Oregon Street • Oshkosh, WI 54902 • 1-800-872-7697 • Phone (920) 236-4200 • Fax (920) 236-4219  
909 Perkins Drive • Mukwonago, WI 53149 • Phone (262) 363-1555 • Fax (262) 363-1556

World Headquarters  
Baldor Electric Company • P.O. Box 2400 • Fort Smith, AR 72902-2400 U.S.A.  
Phone (479) 646-4711 • Fax (479) 648-5792 • International Fax (479) 648-5895  
www.baldor.com