

Standby or Prime Power Features

- Heavy-duty Cummins 4-stroke gas engine, water-cooled
- Brushless synchronous alternators: four-pole construction, dynamically balanced
- Full featured microprocessor based controller: fully programmable for maximum flexibility
- Prototype tested and production tested
- UL2200 available – consult factory
- Optional weather-proof and sound attenuated enclosures available
- Full range of accessories and options available
- Heavy-duty construction for use in prime or standby application
- Manufactured in an ISO-9001 certified facility
- Backed by a world wide network of parts and service centers

Gen Set Ratings

Baldor Genset Model	kW Rating Standby	kW Rating Prime	kW Rating Standby	kW Rating Prime	Voltage Hi-Wye	Voltage Low-Wye	Voltage Delta	Number of Leads	Phase	Hz	Power Factor
	Natural Gas		LP Gas								
IGLC880N-CA	875	800	N/A	N/A	480/277	240/139	N/A	12	3	60	0.8
IGLC880N-CB	875	800	N/A	N/A	440/254	220/127	N/A	12	3	60	0.8
IGLC880N-CB	875	800	N/A	N/A	416/240	208/120	240/120	12	3	60	0.8
IGLC880N-CC	875	800	N/A	N/A	380/220	N/A	N/A	12	3	60	0.8
IGLC880N-CH	875	800	N/A	N/A	600/347	N/A	N/A	12	3	60	0.8
IGLC880N-CXB	750	660	N/A	N/A	380/220	-	N/A	12	3	50	0.8

NOTES: For ratings and voltages not listed above refer to the Gen-Set Selector or consult factory
 Standby ratings do not have an overload capability but can be used for the duration of the utility failure per ISO-3046, DIN6271 and BS5514
 Prime (Unlimited Running Time) ratings are continuous per DIN 6271 and ISO-3046 with 10% overload capacity
 Base Load (Continuous) ratings are continuous per DIN 6271, BS5514 and ISO-8528 with no sustained overload capacity
 Consult factory for Base Load ratings
 Altitude derate is 4% for each 1000 feet over 3000
 Temperature derate is 1% for 10°F over 100°F ambient

Controls Digital Control Module

MEC2 Features

- Large Backlit LCD with alpha-numeric readout
- Microprocessor Based Design
- 16 programmable alarms/shutdowns set points
- 4 programmable inputs
- Alarm horn
- Not in Automatic Alarm
- Digital Three Phase Voltage and Current Monitoring
- Password Protected Front Panel Programming
- 4 Programmable Outputs
- Local Emergency Stop Switch
- Optional NFPA110 Level I

Engine Protections

- Digital Oil Pressure Gauge
- Digital Water Temperature Gauge
- Digital Battery Voltmeter
- Overspeed Shutdown
- Emergency Stop Shutdown
- Loss of Speed Signal
- Overcrank Shutdown

Designed To Meet/Exceed the Standards Below:

- UL 508
- UL 2200
- NFPA 70
- NFPA 110

Engine Technical Data

Manufacturer	Cummins
Engine Model	GTA50-G3
Engine Type	4 cycle, 16 cylinder
Aspiration	Turbocharged and Aftercooled
Configuration	60 Degree Vee
Displacement - cu. in. (liters)	3067 (50.3)
Bore and Stroke - in. (mm)	6.25 x 6.25 (159 x 159)
Compression Ratio	8.5:1
Air Filter Type	Dry
Governor Type	Electronic
Governor Model	Woodward Flowtech
Injection Pump Type/Model	75mm
Frequency Regulation, steady state	+/- 0.25%
Frequency Regulation, no load to full load	Isochronous
Battery Voltage	24 VDC
Water Pump Type	Centrifugal
Coolant Cap. - radiator cooled - gals - liters	TBA
Coolant Capacity - engine only - gals - liters	162 (153)
Oil Pan Capacity - gals - liters	204 - 174 54 - 46
Rec'd Oil Type - SF/CC/CD-10°F to 90°F	10W-40

Engine Operational Values	English 50 Hz	Metric 50 Hz	English 60 Hz	Metric 60 Hz
Maximum ambient temperature - F° - C°	100	38	100	38
Heat rejected to coolant - Btu/min - kW	44,502	782	53,300	936
Heat rejected to aftercooler - Btu/min - kW	5,790	102	9,433	166
Max. power at rated rpm - bhp - kWm	1,144	853	1,334	995
Coolant flow - gpm - lpm	325	1,230	390	1,476
Exhaust temperature - F° - C° (maximum)	1,350	732	1,350	732
Exhaust flow - cfm - m ₃ /min	5,419	2,558	5,753	2,715
Gas pressure required - in. H ₂ O - mm H ₂ O	10 -20	254 - 508	10 -20	254 - 508
Minimum pipe size @ engine - in. - mm	2	51	2	51
Normal oil pressure high - PSI - kPa	50-70	345-483	50-70	345-483

Gen Set Technical Data

Alternator Technical Data

Generator Frame	6	Voltage Regulation NL - FL	0.50%
Exciter	Brushless	Underspeed Protection	Standard
Cooling Fan	Cast alloy aluminum	Overexcitation Protection	Standard
Bearing	Single, double shielded	Overvoltage Protection	Standard
Connection Type	Reconnectable	Loss of Sensing Protection	Standard
Insulation Type	Class H	Overspeed	2250 RPM
Windings	100% copper	Standards	NEMA, IEC, IEEE, CSA, BS
Pitch	2/3	Phase Sequence	A(U), B(V), C(W)
Amortisseur Winding	Full	TIF (1960 Weightings)	<50
Voltage Regulator	MX321	Excitation System	PMG Standard

Alternator Performance Data

	Model IGLC880N-CA	Model IGLC880N-CB	Model IGLC880N-CC	Model IGLC880N-CH
Temperature rise by resistance - °C (Stand-By)	150/40	150/41	150/42	150/43
Generator model number	HCI634H	HCI634J	HCI634K	HCI634J
Generator kW at 130/105/80°C over 40°C amb. (480 Volt , 60Hz)	850/770/680	1040/950/828	1150/1050/900	1040/950/828
SKVA output with 30% voltage dip max. 100% recovery at 60 Hz	2300	2600	3200	2600
Maximum skva at 90% sustained voltage dip	Consult Factory	Consult Factory	Consult Factory	Consult Factory
Subtransient reactance at voltage listed	16.00%	16.00%	15.00%	16.00%
Line - line harmonic maximum total	3.50%	3.50%	3.50%	3.50%

Installation/Application Data

	English 50 Hz	Metric 50 Hz	English 60 Hz	Metric 60 Hz
Ventilation requirements				
a. Cooling airflow required - cfm - l/s (unit mounted radiator)	75,000	35,400	75,000	35,400
b. Combustion air required - cfm - l/s	1960	925	2,358	1,113
Total ventilation requirements - cfm - l/s (a. + b.)	76,960	36,325	77,358	36,513
Maximum cooling air restriction - in.H2O - mm.H2O	0.5	12.8	0.5	12.8
Minimum intake louver size (based on "free area") ft2 - m2	75	7.0	75	7.0
a. Heat rejected to ambient, engine - Btu/min - kW	5,242	92	6,124	108
b. Heat rejected to ambient, generator - Btu/min - kW	4,858	85	5,664	100
Total heat rejection to ambient - Btu/min - kW (a. + b.)	10,100	177	11,788	207

Exhaust system requirements

Exhaust gas flow - cfm - m3/min	5,419	2,558	5,753	2,715
Exhaust temperature (dry manifold) - °F - °C	1,350	732	1350	732
Maximum back pressure - in.hg - mm.hg (inclusive of silencer)	2	50.8	2	50.8
Exhaust outlet size - in. - mm	6	152.4	6	152.4
Emissions - HC - g/hp-hr	Consult Factory		1.91	
Emissions - CO - g/hp-hr	Consult Factory		17.3	
Emissions - NOX - g/hp-hr	Consult Factory		4.74	

Fuel system requirements – see engine operational values for gas pressure requirements

Fuel consumption - 1/4 load - cu.ft/hr - BTU/Hp-hr (natural gas)	3,416	2,688	4,176	3,287
Fuel consumption - 1/2 load - cu.ft/hr - BTU/Hp-hr (natural gas)	6,263	4,929	7,656	6,025
Fuel consumption - 3/4 load - cu.ft/hr - BTU/Hp-hr (natural gas)	8,160	6,422	9,976	7,851
Fuel consumption - Full load - cu.ft/hr - BTU/Hp-hr (natural gas)	9,489	7,468	11,600	9,129

Conversions: Cubic feet of Natural Gas/2.644 = Cubic Feet of LPG and Cubic Feet of LPG/8.533 = Gallons of LPG per hour - "estimated"

Heat Exchanger Cooling system requirements

Minimum raw water (city water) flow - gpm/lps	Consult Factory	Consult Factory	Consult Factory	Consult Factory
Maximum supply water temperature - °F - °C	80°F	12.44°C	80°F	12.44°C

Remote Cooling system requirements

Maximum coolant static head - ft. - m	60	18.3	60	18.3
Ventilation required (based on 25°F temp rise) - cfm - lps	22,444	394	26,197	460

Accessories and Options

Control Panel

- High Coolant Temp. Pre-alarm
- Low Oil Pressure Pre-alarm
- Alarm Horn with Switch
- Remote Start-Stop
- Remote Annunciator

PER NFPA 110

- Run Relay
- Dry Contacts

Engine Exhaust System

- Industrial Silencer
- Residential Silencer
- Critical Silencer
- Exhaust Flex
- Rain Cap
- _____

Generator Accessories

- Main Line Circuit Breaker
- Shunt Trip
- Alternator Heater
- Field Circuit Breaker
- PMG
- _____

Engine Electrical System

- Batteries
- Battery Rack
- Battery Cables
- Battery Charger - Automatic
- Battery Charger - Trickle
- _____

Engine Fuel System

- Flexible Fuel Lines
- _____

Miscellaneous

- Weather protective Enclosure
- Sound Attenuated Enclosure
- Vibration Isolators
- Coolant Heater
- _____

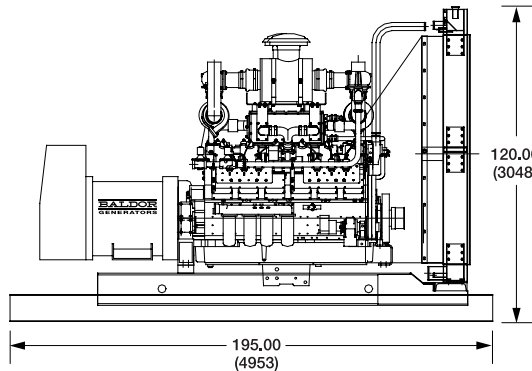
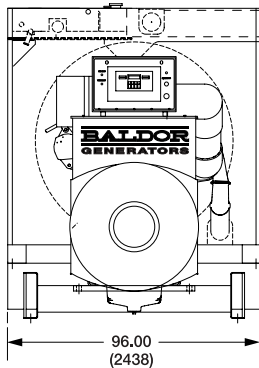

Dimensions – in (mm)

Weight – lbs. (Kg)
21,716 (9850)

Cubes (Approximate)
1300 ft

*Open unit configuration,
accessories not included

Ratings – Standby Ratings: Standby ratings are applicable for supplying emergency power for the duration of a utility power outage. Primary power to the installation is utility supplied. No overload capability for standby rating. Standby ratings in accordance with ISO 3046, BS55114, DIN 6271. **Continuous Power Rating:** Continuous power is the maximum power available for continuous duty. A 10% overload capacity is available for 1 hour out of 12 hours of operation. Prime Power ratings in accordance with ISO 3046, BS55114, DIN 6271. For additional information, please consult factory. Manufacture reserves the right to implement specifications or design changes without notice.

Distributed by:

BALDOR
GENERATORS

3815 Oregon Street • Oshkosh, WI 54902 • 1-800-872-7697 • Phone (920) 236-4200 • Fax (920) 236-4219
909 Perkins Drive • Mukwonago, WI 53149 • Phone (262) 363-1555 • Fax (262) 363-1556

World Headquarters

Baldor Electric Company • P.O. Box 2400 • Fort Smith, AR 72902-2400 U.S.A.
Phone (479) 646-4711 • Fax (479) 648-5792 • International Fax (479) 648-5895

www.baldor.com