

Standby Power Features

- | | |
|---|---|
| <ul style="list-style-type: none"> • Heavy-duty industrial diesel engine • Brushless synchronous alternators: four-pole construction, dynamically balanced • Prototype tested and production tested • Gen-set accepts rated load in one step • Optional weather-proof enclosures available | <ul style="list-style-type: none"> • Accessories and options available • Heavy-duty construction for use in standby application • Manufactured in an ISO-9001 certified facility • Backed by a world wide network of parts and service center |
|---|---|

Gen Set Ratings

Baldor Genset Model	kW Rating Standby	Voltage Delta	Number of Leads	Phase	Hz	Power Factor
<i>Standard</i>						
DLC100-JD	100	240/120	4	1	60	1

NOTES: For ratings and voltages not listed above consult Baldor
 Standby ratings do not have an overload capability but can be used for the duration of the utility failure per ISO-3046, DIN6271 and BS5514
 Base Load (Continuous) ratings are continuous per DIN 6271, BS5514 and ISO-8528 with no sustained overload capacity
 Consult factory for Base Load ratings
 Altitude derate is 4% for each 1000 feet over 5000
 Temperature derate is 1% for 10°F over 100°F ambient

Controls Analog Auto-Start Control

Features

- NEMA 1 type enclosure, vibration isolated
- Hinged front access allow easy access to wiring
- 3.5" AC meters with +/- 2% accuracy.
- Ammeter/Voltmeter selector switch for monitoring line voltage and current in each phase
- AC meters comply with ANSI C39.1 and IP H2
- Engine gauges comply with SAE specifications

Engine Monitoring

- Engine oil pressure gauge
- Engine coolant temperature gauge
- Engine battery voltmeter
- Engine operating hours
- Low oil pressure shutdown indication
- High coolant temperature shutdown indication
- Over speed shutdown indication
- Over crank shutdown indication
- Engine running indication

- Low fuel level indication (optional)
- Fuel tank leak indication (optional)
- Low coolant level shutdown indication (optional)

Generator Monitoring

- AC voltmeter
- AC ammeter
- AC frequency

Engine Protections

- Low oil pressure shutdown
- High coolant temperature shutdown
- Engine over speed shutdown
- Engine over crank shutdown

Designed To Meet/Exceed the Standards Below:

- UL 508
- UL 2200
- Operating temperature range -40°C to +85°C

Engine Technical Data

Manufacturer	John Deere
Engine Model	PE6068TF150
Engine Type	4 cycle, 6 cylinders
Engine Horsepower	165
Aspiration	Turbocharged
Configuration	In-line
Displacement - cu. in. (liters)	414 (6.8)
Bore and Stroke - in. (mm)	4.19 x 5 (106 x 127)
Compression Ratio	17.0:1
Air Filter Type	Dry
Governor Type	Mechanical
Governor Model	Stanadyne
Injection Pump Type/Model	Direct Injection
Frequency Regulation, steady state	+/-0.5%
Frequency Regulation, no load to full load	4% Droop (Opt. Electronic Governor)
Battery Voltage	12 VDC
Water Pump Type	Centrifugal
Coolant Cap. - radiator cooled - gals - liters	4.9 5.9
Coolant Capacity - engine only - gals - liters	3.0 11.4
Oil Pan Capacity - gals - liters	4.3 16.1
Rec'd Oil Type - SF/CC/CD-10°F to 90°F	10W-40

Engine Operational V	Metric 60 Hz	60 Hz
Maximum ambient temperature - F° - C°	104/122	40/50
Heat rejected to coolant - Btu/min - kWm	3525	62
Max. power at rated rpm - BHP - kWm	165	123.09
Coolant flow - gpm - l/s at 1 PSI	38	2.9
Exhaust temperature - F° - C°	1101	544
Exhaust flow - cfm - l/s	787	371
Normal oil press. (low/high) - PSI - kPa	15/50	105/345
Max fuel flow to injection pump - gph - kg/hr	30	96

Gen Set Technical Data

Alternator Technical Data

Generator Frame	2	Voltage Regulation NL - FL	± 1%
Exciter	Brushless	Underspeed Protection	Standard
Cooling Fan	Cast alloy aluminum	Overexcitation Protection	Optional
Bearing	Single, double shielded	Overvoltage Protection	Optional
Connection Type	Reconnectable	Loss of Sensing Protection	Standard
Insulation Type	Class H	Overspeed	2250 RPM
Windings	100% copper	Standards	NEMA, IEC, IEEE, CSA, BS
Pitch	2/3	Phase Sequence	A(U), B(V), C(W)
Amortisseur Winding	Full	TIF (1960 Weightings)	<50
Voltage Regulator	SA465	Excitation System	PMG - N/A

Alternator Performance Data	Model DLC100-JD
Temperature rise by resistance - °C (Stand-By)	150/40
Generator model number	UCI274C
Generator kW at 150/125/105°C/40°C ambient - 240/120V, 1P	100 / 90 / 75
SKVA output with 30% voltage dip max. 100% recovery at 60 Hz	Consult Baldor
Maximum skva at 90% sustained voltage dip	Consult Baldor
Subtransient reactance at voltage listed	13%
Line - line harmonic maximum total	5.00%

Installation/Application Data	English 60 Hz	Metric 60 Hz
Ventilation requirements		
a. Cooling airflow required - cfm - l/s (unit mounted radiator)	4983	2351
b. Combustion air required - cfm - l/s	270	127
Total ventilation requirements - cfm - l/s (a. + b.)	5253	2478
Maximum cooling air restriction - in.H ₂ O - in.hg	0.5	0.037
Recommended "free area" intake louver size ft ² - m ²	6.3	0.585
a. Heat rejected to ambient, engine - Btu/min - kWm	1025	18
b. Heat rejected to ambient, generator - Btu/min - kWm	285	5
Total heat rejection to ambient - Btu/min (a. + b.)	1310	23
Exhaust system requirements		
Exhaust gas flow - cfm - l/s	787	371
Exhaust temperature (dry manifold) - °F - °C	1011	544
Maximum back pressure - in.hg - kPa (inclusive of silencer)	3	41.0
Exhaust outlet size - in. - mm	4	101.6
Emissions - NO _x - g/BHP-hr - g/kW-hr	Meets EPA Tier One/CARB Consult Baldor for actual values	
Emissions - HC - g/BHP-hr - g/kW-hr		
Emissions - CO - g/BHP-hr - g/kW-hr		
Emissions - Particulates - PM - g/BHP-hr - g/kW-hr		
Fuel system requirements		
Fuel consumption - 1/4 load - gph - Lph	2.4	9.1
Fuel consumption - 1/2 load - gph - Lph	4.2	16
Fuel consumption - 3/4 load - gph - Lph	6.3	23.8
Fuel consumption - full load - gph - Lph	8.2	30.9
Heat Exchanger Cooling system requirements		
Minimum raw water (city water) flow - gpm - lps	Consult Baldor	Consult Baldor
Maximum supply water temperature - °F - °C	80°F	12.44°C
Remote Cooling system requirements		
Maximum coolant static head - ft. - m	46	14
Ventilation required (based on 25°F temp rise) - cfm - lps	2911	51

Accessories and Options

Controls Analog Auto-Start

Control Panel

- Run Relay - 10 Amp
- Dry Contacts For Alarms
- Remote E-Stop
- Remote Annunciator

Engine Exhaust System

- Industrial Silencer
- Critical Silencer
- Exhaust Flex
- Exhaust Extension
- Rain Cap

Generator Accessories

- Main Line Circuit Breaker
- Space Heater

Engine Electrical System

- Batteries
- Battery Rack
- Battery Cables
- Battery Charger – Automatic

Engine Fuel System

- Sub-Base Fuel Tank
- Flexible Fuel Lines

Miscellaneous

- Weather Protective Enclosure
- Coolant Heater

- _____
- _____
- _____
- _____
- _____
- _____

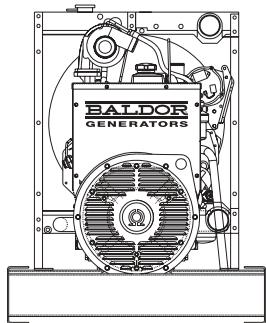

48.0 (1219)

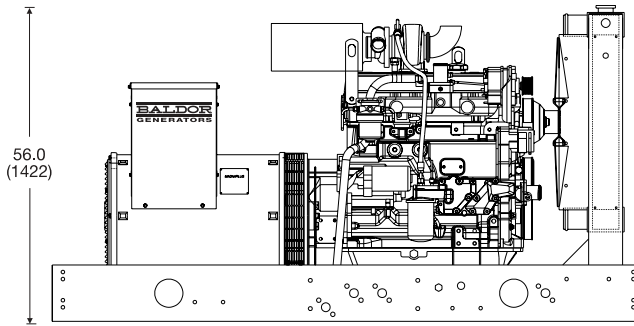

56.0
(1422)

108 (2743)

Dimensions – in (mm)

Weight – lbs. (Kg)
2700 (1225)

Cubes (Approximate)
150.5 ft

*Open unit configuration,
accessories not included

Distributed by:



3815 Oregon Street • Oshkosh, WI 54902 • 1-800-872-7697 • Phone (920) 236-4200 • Fax (920) 236-4219
909 Perkins Drive • Mukwonago, WI 53149 • Phone (262) 363-1555 • Fax (262) 363-1556

World Headquarters

Baldor Electric Company • P.O. Box 2400 • Fort Smith, AR 72902-2400 U.S.A.
Phone (479) 646-4711 • Fax (479) 648-5792 • International Fax (479) 648-5895

www.baldor.com