

## Standby or Prime Power Features

- Heavy-duty industrial diesel engine
- Brushless synchronous alternators: four-pole construction, dynamically balanced
- Full featured microprocessor based controller: fully programmable for maximum flexibility
- Prototype tested and production tested
- Gen-set accepts rated load in one step
- UL2200 available – consult factory
- Optional weather-proof and sound attenuated enclosures available
- Full range of accessories and options available
- Heavy-duty construction for use in prime or standby application
- Manufactured in an ISO-9001 certified facility
- Backed by a world wide network of parts and service center

## Gen Set Ratings

Baldor Genset Model	kW Rating Standby	kW Rating Prime	Voltage Hi-Wye	Voltage Low-Wye	Voltage Delta	Number of Leads	Phase	Hz	Power Factor
IDLC30-JDA	30	25	480/277	240/139	N/A	12	3	60	0.8
IDLC30-JDB	30	25	440/254	220/127	N/A	12	3	60	0.8
IDLC30-JDC	30	25	416/240	208/120	240/120	12	3	60	0.8
IDLC30-JDC	30	25	380/220	N/A	N/A	12	3	60	0.8
IDLC30-JDE	30	25	N/A	N/A	240/120	4	1	60	1.0
IDLC30-JDH	30	25	600/347	N/A	N/A	12	3	60	0.8
IDLC30-JDXB/A	25	20	380/220	N/A	N/A	12	3	50	0.8

**NOTES:** For ratings and voltages not listed above refer to the Gen-Set Selector or consult factory  
 Standby ratings do not have an overload capability but can be used for the duration of the utility failure per ISO-3046, DIN6271 and BS5514  
 Prime (Unlimited Running Time) ratings are continuous per DIN 6271 and ISO-3046 with 10% overload capacity  
 Base Load (Continuous) ratings are continuous per DIN 6271, BS5514 and ISO-8528 with no sustained overload capacity  
 Consult factory for Base Load ratings  
 Altitude derate is 4% for each 1000 feet over 5000  
 Temperature derate is 1% for 10°F over 100°F ambient

# Controls Digital Control Module

## MEC2 Features

- Large Backlit LCD with alpha-numeric readout
- Microprocessor Based Design
- 16 programmable alarms/shutdowns set points
- 4 programmable inputs
- Alarm horn
- Not in Automatic Alarm
- Digital Three Phase Voltage and Current Monitoring
- Password Protected Front Panel Programming
- 4 Programmable Outputs
- Local Emergency Stop Switch
- Optional NFPA110 Level I

## Engine Protections

- Digital Oil Pressure Gauge
- Digital Water Temperature Gauge
- Digital Battery Voltmeter
- Overspeed Shutdown
- Emergency Stop Shutdown
- Loss of Speed Signal
- Overcrank Shutdown

## Designed To Meet/Exceed the Standards Below:

- UL 508
- UL 2200
- NFPA 70
- NFPA 110

## Engine Technical Data

Manufacturer	John Deere
Engine Model	PE4045DF150
Engine Type	4 cycle, 4 cylinders
Engine Horsepower	71
Aspiration	Natural
Configuration	In-line
Displacement - cu. in. (liters)	276 (4.5)
Bore and Stroke - in. (mm)	4.19 x 5 (106 x 127)
Compression Ratio	17.6:1
Air Filter Type	Dry
Governor Type	Mechanical
Governor Model	Stanadyne
Injection Pump Type/Model	Direct Injection
Frequency Regulation, steady state	+/-0.5%
Frequency Regulation, no load to full load	4% Droop (Opt. Electronic Governor)
Battery Voltage	12 VDC
Water Pump Type	Centrifugal
Coolant Cap. - radiator cooled - gals - liters	4.30 16.3
Coolant Capacity - engine only - gals - liters	2.25 8.5
Oil Pan Capacity - gals - liters	2.00 7.6
Rec'd Oil Type - SF/CC/CD-10°F to 90°F	10W-40

Engine Operational Values	English 50 Hz	Metric 50 Hz	English 60 Hz	Metric 60 Hz
Maximum ambient temperature - F° - C°	104/122	40/50	104/122	40/50
Heat rejected to coolant - Btu/min - kWm	1535	27	1820	32
Max. power at rated rpm - BHP - kWm	59	44.01	71	52.97
Coolant flow - gpm - l/s at 1 PSI	32	2	38	2.4
Exhaust temperature - F° - C°	1049	565	1130	595
Exhaust flow - cfm - l/s	258	122	318	150
Normal oil press. (low/high) - PSI - kPa	15/50	105/345	15/50	105/345
Max fuel flow to injection pump - gph - kg/hr	29	93	30	96

# Gen Set Technical Data

## Alternator Technical Data

Generator Frame	18/22	Voltage Regulation NL - FL	± 1.5%
Exciter	Brushless	Underspeed Protection	Standard
Cooling Fan	Cast alloy aluminum	Overexcitation Protection	Optional
Bearing	Single, double shielded	Overvoltage Protection	Optional
Connection Type	Reconnectable	Loss of Sensing Protection	Standard
Insulation Type	Class H	Overspeed	2250 RPM
Windings	100% copper	Standards	NEMA, IEC, IEEE, CSA, BS
Pitch	2/3	Phase Sequence	A(U), B(V), C(W)
Amortisseur Winding	Full	TIF (1960 Weightings)	<50
Voltage Regulator	SX460	Excitation System	PMG - optional

Alternator Performance Data	Model IDLC30-JDA	Model IDLC30-JDB	Model IDLC30-JDC	Model IDLC30-JDH
Temperature rise by resistance - °C (Stand-By)	150/40	150/40	150/40	150/40
Generator model number	BCI184F	BCI184G	UCI224C	UCI224C
Generator kW at 125/105/80°C over 40°C ambient (480 Volt , 60Hz)	28/26/24	30/27.5/24.5	44/38.4/33.6	44/38.4/33.6
SKVA output with 30% voltage dip max. 100% recovery at 60 Hz	65	77	140	140
Maximum skva at 90% sustained voltage dip	Consult Baldor	Consult Baldor	Consult Baldor	Consult Baldor
Subtransient reactance at voltage listed	12.00%	10.00%	13.00%	13.00%
Line - line harmonic maximum total	5.00%	5.00%	5.00%	5.00%

Installation/Application Data	English 50 Hz	Metric 50 Hz	English 60 Hz	Metric 60 Hz
<b>Ventilation requirements</b>				
a. Cooling airflow required - cfm - l/s (unit mounted radiator)	2597	1226	2597	1226
b. Combustion air required - cfm - l/s	84	40	103	49
<b>Total ventilation requirements - cfm - l/s (a. + b.)</b>	<b>2681</b>	<b>1266</b>	<b>2700</b>	<b>1275</b>
Maximum cooling air restriction - in.H <sub>2</sub> O - in.hg	0.5	0.037	0.5	0
Recommended "free area" intake louver size ft <sup>2</sup> - m <sup>2</sup>	6.3	0.585	6.3	1
a. Heat rejected to ambient, engine - Btu/min - kWm	365	6.4	500	9
b. Heat rejected to ambient, generator - Btu/min - kWm	94	1.65	114	2
<b>Total heat rejection to ambient - Btu/min (a. + b.)</b>	<b>459</b>	<b>8</b>	<b>614</b>	<b>10.8</b>

<b>Exhaust system requirements</b>				
Exhaust gas flow - cfm - l/s	258	122	318	150
Exhaust temperature (dry manifold) - °F - °C	1049	565	1130	595
Maximum back pressure - in.hg - kPa (inclusive of silencer)	3.0	41.0	3.0	41.0
Exhaust outlet size - in. - mm	2.5	63.5	2.5	63.5
Emissions - NO <sub>x</sub> - g/BHP-hr - g/kW-hr	Not Regulated		Meets EPA Tier One/CARB Consult factory for actual values	
Emissions - HC - g/BHP-hr - g/kW-hr				
Emissions - CO - g/BHP-hr - g/kW-hr				
Emissions - Particulates - PM - g/BHP-hr - g/kW-hr				

<b>Fuel system requirements</b>				
Fuel consumption - 1/4 load - gph - Lph	0.8	3.1	1.2	4.4
Fuel consumption - 1/2 load - gph - Lph	1.6	6.0	2.0	7.7
Fuel consumption - 3/4 load - gph - Lph	2.3	8.5	2.9	10.8
Fuel consumption - full load - gph - Lph	3.0	11.4	3.7	13.9

<b>Heat Exchanger Cooling system requirements</b>				
Minimum raw water (city water) flow - gpm - lps	Consult Baldor	Consult Baldor	Consult Baldor	Consult Baldor
Maximum supply water temperature - °F - °C	80°F	12.44°C	80°F	12.44°C

<b>Remote Cooling system requirements</b>				
Maximum coolant static head - ft. - m	46	14	46	14
Ventilation required (based on 25°F temp rise) - cfm - lps	1020	18	1364	24

# Accessories and Options

## Control Panel

- Louver Relay – 10 Amp
- Run Relay – 10 Amp
- Dry Contacts For Alarms
- Remote E-Stop
- Control Panel Heater
- Tachometer
- Remote Annunciator
- Remote Communication
- Panel Lights W/Switch
- Generator Voltage Adjust
- Modem For Remote Communication

## Engine Exhaust System

- Industrial Silencer
- Residential Silencer
- Critical Silencer
- Exhaust Flex
- Exhaust Extension
- Rain Cap
- \_\_\_\_\_

## Generator Accessories

- Main Line Circuit Breaker
- Exciter Field Circuit Breaker
- Ground Fault Module W/Breaker Shunt Trip
- Ground Fault Module W/O Breaker Shunt Trip
- Reconnectable Link Bars
- Drip Cover IP22
- Manual Voltage Control
- Space Heater
- RTD's Stator Windings
- RTD's Bearing (Rear)
- PMG
- MVC300 Manual Voltage Control

## Engine Electrical System

- Batteries
- Battery Rack
- Battery Cables
- Battery Charger - Automatic
- Battery Charger - Trickle
- \_\_\_\_\_

## Engine Fuel System

- Weather Proof Enclosure
- Sound Attenuated Enclosure
- Trailer Mounted
- Vibration Isolators
- Coolant Heater
- Bypass Oil Filter
- Export Crating
- \_\_\_\_\_
- \_\_\_\_\_
- \_\_\_\_\_
- \_\_\_\_\_

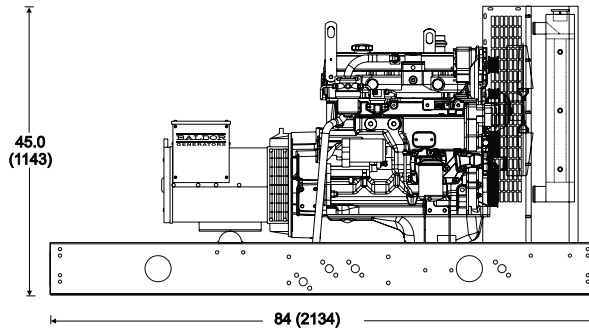
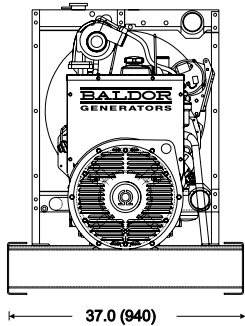

Dimensions – in (mm)

Weight – lbs. (Kg)  
1465 (665)

Cubes (Approximate)  
80.9 ft

\*Open unit configuration,  
accessories not included

*Distributed by:*



3815 Oregon Street • Oshkosh, WI 54902 • 1-800-872-7697 • Phone (920) 236-4200 • Fax (920) 236-4219  
909 Perkins Drive • Mukwonago, WI 53149 • Phone (262) 363-1555 • Fax (262) 363-1556

World Headquarters

Baldor Electric Company • P.O. Box 2400 • Fort Smith, AR 72902-2400 U.S.A.  
Phone (479) 646-4711 • Fax (479) 648-5792 • International Fax (479) 648-5895

www.baldor.com