

Standby or Prime Power Features

- Heavy-duty industrial diesel engine
- Brushless synchronous alternators: four-pole construction, dynamically balanced
- Full featured microprocessor based controller: fully programmable for maximum flexibility
- Prototype tested and production tested
- Gen-set accepts rated load in one step
- UL2200 available – consult factory
- Optional weather-proof and sound attenuated enclosures available
- Full range of accessories and options available
- Heavy-duty construction for use in prime or standby application
- Manufactured in an ISO-9001 certified facility
- Backed by a world wide network of parts and service center

Gen Set Ratings

Baldor Genset Model	kW Rating Standby	kW Rating Prime	Voltage Hi-Wye	Voltage Low-Wye	Voltage Delta	Number of Leads	Phase	Hz	Power Factor
IDLC80-JDB	80	70	480/277	240/139	N/A	12	3	60	0.8
IDLC80-JDB	80	70	440/254	220/127	N/A	12	3	60	0.8
IDLC80-JDC	80	70	416/240	208/120	240/120	12	3	60	0.8
IDLC80-JDC	80	70	380/220	N/A	N/A	12	3	60	0.8
IDLC80-JDF	80	70	N/A	N/A	240/120	4	1	60	1.0
IDLC80-JDH	80	70	600/347	N/A	N/A	12	3	60	0.8
IDLC80-JDXB/A	60	50	380/220	N/A	N/A	12	3	50	0.8

NOTES: For ratings and voltages not listed above refer to the Gen-Set Selector or consult factory
 Standby ratings do not have an overload capability but can be used for the duration of the utility failure per ISO-3046, DIN6271 and BS5514
 Prime (Unlimited Running Time) ratings are continuous per DIN 6271 and ISO-3046 with 10% overload capacity
 Base Load (Continuous) ratings are continuous per DIN 6271, BS5514 and ISO-8528 with no sustained overload capacity
 Consult factory for Base Load ratings
 Altitude derate is 4% for each 1000 feet over 5000
 Temperature derate is 1% for 10°F over 100°F ambient

Controls Digital Control Module

MEC2 Features

- Large Backlit LCD with alpha-numeric readout
- Microprocessor Based Design
- 16 programmable alarms/shutdowns set points
- 4 programmable inputs
- Alarm horn
- Not in Automatic Alarm
- Digital Three Phase Voltage and Current Monitoring
- Password Protected Front Panel Programming
- 4 Programmable Outputs
- Local Emergency Stop Switch
- Optional NFPA110 Level I

Engine Protections

- Digital Oil Pressure Gauge
- Digital Water Temperature Gauge
- Digital Battery Voltmeter
- Overspeed Shutdown
- Emergency Stop Shutdown
- Loss of Speed Signal
- Overcrank Shutdown

Designed To Meet/Exceed the Standards Below:

- UL 508
- UL 2200
- NFPA 70
- NFPA 110

Engine Technical Data

Manufacturer	John Deere
Engine Model	PE4045TF250
Engine Type	4 cycle, 4 cylinders
Engine Horsepower	122
Aspiration	Turbocharged
Configuration	In-line
Displacement - cu. in. (liters)	276 (4.5)
Bore and Stroke - in. (mm)	4.19 x 5 (106 x 127)
Compression Ratio	17.0:1
Air Filter Type	Dry
Governor Type	Mechanical
Governor Model	Stanadyne
Injection Pump Type/Model	Direct Injection
Frequency Regulation, steady state	+/-0.5%
Frequency Regulation, no load to full load	4% Droop (Opt. Electronic Governor)
Battery Voltage	12 VDC
Water Pump Type	Centrifugal
Coolant Cap. - radiator cooled - gals - liters	4.9 5.9
Coolant Capacity - engine only - gals - liters	2.3 8.5
Oil Pan Capacity - gals - liters	3.3 12.3
Rec'd Oil Type - SF/CC/CD-10°F to 90°F	10W-40

Engine Operational Values	English 50 Hz	Metric 50 Hz	English 60 Hz	Metric 60 Hz
Maximum ambient temperature - F° - C°	104/122	40/50	104/122	40/50
Heat rejected to coolant - Btu/min - kWm	2389	42	2959	52
Max. power at rated rpm - BHP - kWm	94	70.12	122	91.01
Coolant flow - gpm - l/s at 1 PSI	32	2	38	2.4
Exhaust temperature - F° - C°	1050	565	1026	552
Exhaust flow - cfm - l/s	409	193	614	290
Normal oil press. (low/high) - PSI - kPa	15/50	105/345	15/50	105/345
Max fuel flow to injection pump - gph - kg/hr	29	93	30	96

Gen Set Technical Data

Alternator Technical Data

Generator Frame	22	Voltage Regulation NL - FL	+/- 1.5%
Exciter	Brushless	Underspeed Protection	Standard
Cooling Fan	Cast alloy aluminum	Overexcitation Protection	Optional
Bearing	Single, double shielded	Overvoltage Protection	Optional
Connection Type	Reconnectable	Loss of Sensing Protection	Standard
Insulation Type	Class H	Overspeed	2250 RPM
Windings	100% copper	Standards	NEMA, IEC, IEEE, CSA, BS
Pitch	2/3	Phase Sequence	A(U), B(V), C(W)
Amortisseur Winding	Full	TIF (1960 Weightings)	<50
Voltage Regulator	SX460	Excitation System	PMG - optional

Alternator Performance Data	Model IDLC80-JDB	Model IDLOC80-JDC	Model IDLC80-JDF	Model IDLC80-JDH
Temperature rise by resistance - °C (Stand-By)	150/40	150/40	150/40	150/40
Generator model number	UCI224G	UCI274C	UCI224G	UCI224G
Generator kW at 125/105/80°C over 40°C ambient (480 Volt , 60Hz)	83/76/66	100/90/78	83/76/66	83/76/66
SKVA output with 30% voltage dip max. 100% recovery at 60 Hz	310	345	310	310
Maximum skva at 90% sustained voltage dip	Consult Baldor	Consult Baldor	Consult Baldor	Consult Baldor
Subtransient reactance at voltage listed	11.00%	13.00%	11.00%	11.00%
Line - line harmonic maximum total	5.00%	5.00%	5.00%	5.00%

Installation/Application Data	English 50 Hz	Metric 50 Hz	English 60 Hz	Metric 60 Hz
Ventilation requirements				
a. Cooling airflow required - cfm - l/s (unit mounted radiator)	5342	2521	5342	2521
b. Combustion air required - cfm - l/s	220	104	293	139
Total ventilation requirements - cfm - l/s (a. + b.)	5562	2625	5635	2660
Maximum cooling air restriction - in.H ₂ O - in.hg	0.5	0.037	0.5	0.037
Recommended "free area" intake louver size ft ² - m ²	6.3	0.585	6.3	0.585
a. Heat rejected to ambient, engine - Btu/min - kWm	779	14	918	16
b. Heat rejected to ambient, generator - Btu/min - kWm	185	3.25	228	4
Total heat rejection to ambient - Btu/min (a. + b.)	964	17.25	1146	20
Exhaust system requirements				
Exhaust gas flow - cfm - l/s	409	193	614	290
Exhaust temperature (dry manifold) - °F - °C	1050	565	1026	552
Maximum back pressure - in.hg - kPa (inclusive of silencer)	3	41	3	41
Exhaust outlet size - in. - mm	4	101.6	4	101.6
Emissions - NO _x - g/BHP-hr - g/kW-hr	Not Regulated		Meets EPA Tier One/CARB Consult factory for actual values	
Emissions - HC - g/BHP-hr - g/kW-hr				
Emissions - CO - g/BHP-hr - g/kW-hr				
Emissions - Particulates - PM - g/BHP-hr - g/kW-hr				
Fuel system requirements				
Fuel consumption - 1/4 load - gph - Lph	1.4	5.5	1.8	6.9
Fuel consumption - 1/2 load - gph - Lph	2.5	9.3	3.3	12.6
Fuel consumption - 3/4 load - gph - Lph	3.5	13.3	4.8	18.0
Fuel consumption - full load - gph - Lph	4.8	18.0	6.2	23.5
Heat Exchanger Cooling system requirements				
Minimum raw water (city water) flow - gpm - lps	Consult Factory	Consult Factory	Consult Factory	Consult Factory
Maximum supply water temperature - °F - °C	80°F	12.44°C	80°F	12.44°C
Remote Cooling system requirements				
Maximum coolant static head - ft. - m	46	14	46	14
Ventilation required (based on 25°F temp rise) - cfm - lps	2547	44	2547	44

Accessories and Options

Control Panel

- Louver Relay – 10 Amp
- Run Relay – 10 Amp
- Dry Contacts For Alarms
- Remote E-Stop
- Control Panel Heater
- Tachometer
- Remote Annunciator
- Remote Communication
- Panel Lights W/Switch
- Generator Voltage Adjust
- Modem For Remote Communication

Engine Exhaust System

- Industrial Silencer
- Residential Silencer
- Critical Silencer
- Exhaust Flex
- Exhaust Extension
- Rain Cap
- _____

Generator Accessories

- Main Line Circuit Breaker
- Exciter Field Circuit Breaker
- Ground Fault Module W/Breaker Shunt Trip
- Ground Fault Module W/O Breaker Shunt Trip
- Reconnectable Link Bars
- Drip Cover IP22
- Manual Voltage Control
- Space Heater
- RTD's Stator Windings
- RTD's Bearing (Rear)
- PMG
- MVC300 Manual Voltage Control

Engine Electrical System

- Batteries
- Battery Rack
- Battery Cables
- Battery Charger - Automatic
- Battery Charger - Trickle
- _____

Engine Fuel System

- Weather Proof Enclosure
- Sound Attenuated Enclosure
- Trailer Mounted
- Vibration Isolators
- Coolant Heater
- Bypass Oil Filter
- Export Crating
- _____
- _____
- _____
- _____

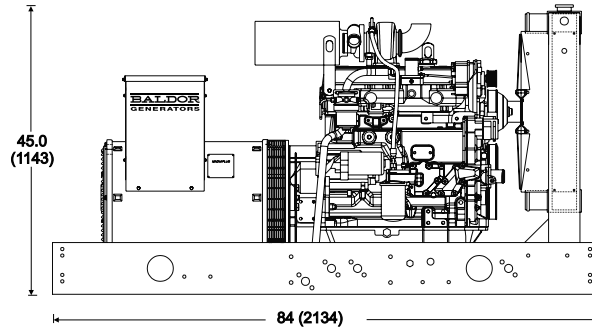
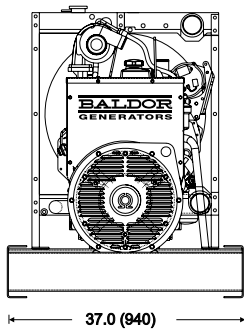

Dimensions – in (mm)

Weight – lbs. (Kg)
2038 (825)

Cubes (Approximate)
80.9 ft

*Open unit configuration,
accessories not included

Distributed by:



3815 Oregon Street • Oshkosh, WI 54902 • 1-800-872-7697 • Phone (920) 236-4200 • Fax (920) 236-4219
909 Perkins Drive • Mukwonago, WI 53149 • Phone (262) 363-1555 • Fax (262) 363-1556

World Headquarters

Baldor Electric Company • P.O. Box 2400 • Fort Smith, AR 72902-2400 U.S.A.
Phone (479) 646-4711 • Fax (479) 648-5792 • International Fax (479) 648-5895

www.baldor.com