

Standby or Prime Power Features

- Heavy-duty industrial diesel engine
- Brushless synchronous alternators: four-pole construction, dynamically balanced
- Full featured microprocessor based controller: fully programmable for maximum flexibility
- Prototype tested and production tested
- Gen-set accepts rated load in one step
- UL2200 available – consult factory
- Optional weather-proof and sound attenuated enclosures available
- Full range of accessories and options available
- Heavy-duty construction for use in prime or standby application
- Manufactured in an ISO-9001 certified facility
- Backed by a world wide network of parts and service center

Gen Set Ratings

Baldor Genset Model	kW Rating Standby	kW Rating Prime	Voltage Hi-Wye	Voltage Low-Wye	Voltage Delta	Number of Leads	Phase	Hz	Power Factor
IDLC125-JDB	125	110	480/277	240/139	N/A	12	3	60	0.8
IDLC125-JDB	125	110	440/254	220/127	N/A	12	3	60	0.8
IDLC125-JDB	125	110	416/240	208/120	240/120	12	3	60	0.8
IDLC125-JDC	125	110	380/220	N/A	N/A	12	3	60	0.8
IDLC125-JDF	125	110	N/A	N/A	240/120	4	1	60	1.0
IDLC125-JDH	125	110	600/347	N/A	N/A	12	3	60	0.8
IDLC125-JDXA	90	80	380/220	N/A	N/A	12	3	50	0.8

NOTES: For ratings and voltages not listed above refer to the Gen-Set Selector or consult factory
 Standby ratings do not have an overload capability but can be used for the duration of the utility failure per ISO-3046, DIN6271 and BS5514
 Prime (Unlimited Running Time) ratings are continuous per DIN 6271 and ISO-3046 with 10% overload capacity
 Base Load (Continuous) ratings are continuous per DIN 6271, BS5514 and ISO-8528 with no sustained overload capacity
 Consult factory for Base Load ratings
 Altitude derate is 4% for each 1000 feet over 5000
 Temperature derate is 1% for 10°F over 100°F ambient

Controls Digital Control Module

MEC2 Features

- Large Backlit LCD with alpha-numeric readout
- Microprocessor Based Design
- 16 programmable alarms/shutdowns set points
- 4 programmable inputs
- Alarm horn
- Not in Automatic Alarm
- Digital Three Phase Voltage and Current Monitoring
- Password Protected Front Panel Programming
- 4 Programmable Outputs
- Local Emergency Stop Switch
- Optional NFPA110 Level I

Engine Protections

- Digital Oil Pressure Gauge
- Digital Water Temperature Gauge
- Digital Battery Voltmeter
- Overspeed Shutdown
- Emergency Stop Shutdown
- Loss of Speed Signal
- Overcrank Shutdown

Designed To Meet/Exceed the Standards Below:

- UL 508
- UL 2200
- NFPA 70
- NFPA 110

Engine Technical Data

Manufacturer	John Deere
Engine Model	PE6068TF250
Engine Type	4 cycle, 6 cylinders
Engine Horsepower	190
Aspiration	Turbocharged
Configuration	In-line
Displacement - cu. in. (liters)	414 (6.8)
Bore and Stroke - in. (mm)	4.19 x 5 (106 x 127)
Compression Ratio	17.0:1
Air Filter Type	Dry
Governor Type	Mechanical
Governor Model	Stanadyne
Injection Pump Type/Model	Direct Injection
Frequency Regulation, steady state	+/-0.5%
Frequency Regulation, no load to full load	4% Droop (Opt. Electronic Governor)
Battery Voltage	12 VDC
Water Pump Type	Centrifugal
Coolant Cap. - radiator cooled - gals - liters	4.9 18.5
Coolant Capacity - engine only - gals - liters	3.0 11.4
Oil Pan Capacity - gals - liters	4.3 16.1
Rec'd Oil Type - SF/CC/CD-10°F to 90°F	10W-40

Engine Operational Values	English 50 Hz	Metric 50 Hz	English 60 Hz	Metric 60 Hz
Maximum ambient temperature - F° - C°	104/122	40/50	104/122	40/50
Heat rejected to coolant - Btu/min - kWm	3412	60	4324	76
Max. power at rated rpm - BHP - kWm	139	103.69	190	141.74
Coolant flow - gpm - l/s at 1 PSI	38	2	46	2.9
Exhaust temperature - F° - C°	1098	592	1112	600
Exhaust flow - cfm - l/s	674	318	918	433
Normal oil press. (low/high) - PSI - kPa	15/50	105/345	15/50	105/345
Max fuel flow to injection pump - gph - kg/hr	29	93	30	96

Gen Set Technical Data

Alternator Technical Data

Generator Frame	27	Voltage Regulation NL - FL	+/- 1.5%
Exciter	Brushless	Underspeed Protection	Standard
Cooling Fan	Cast alloy aluminum	Overexcitation Protection	Optional
Bearing	Single, double shielded	Overvoltage Protection	Optional
Connection Type	Reconnectable	Loss of Sensing Protection	Standard
Insulation Type	Class H	Overspeed	2250 RPM
Windings	100% copper	Standards	NEMA, IEC, IEEE, CSA, BS
Pitch	2/3	Phase Sequence	A(U), B(V), C(W)
Amortisseur Winding	Full	TIF (1960 Weightings)	<50
Voltage Regulator	SX460	Excitation System	PMG - optional

Alternator Performance Data

	Model IDLC125-JDB	Model IDLC125-JDC	Model IDLC125-JDF	Model IDLC125-JDH
Temperature rise by resistance - °C (Stand-By)	150/40	150/40	150/40	150/40
Generator model number	UCI274E	UCI274F	UCI274E	UCI274E
Generator kW at 125/105/80°C over 40°C ambient (480 Volt , 60Hz)	143/128/110	165/150/128	143/128/110	143/128/110
SKVA output with 30% voltage dip max. 100% recovery at 60 Hz	500	600	500	500
Maximum skva at 90% sustained voltage dip	Consult Baldor	Consult Baldor	Consult Baldor	Consult Baldor
Subtransient reactance at voltage listed	14.00%	12.00%	14.00%	14.00%
Line - line harmonic maximum total	5.00%	5.00%	5.00%	5.00%

• Consult factory for oversized alternator adders.

Installation/Application Data

	English 50 Hz	Metric 50 Hz	English 60 Hz	Metric 60 Hz
Ventilation requirements				
a. Cooling airflow required - cfm - l/s (unit mounted radiator)	8500	4012	8500	4012
b. Combustion air required - cfm - l/s	350	166	452	214
Total ventilation requirements - cfm - l/s (a. + b.)	8850	4178	8952	4226
Maximum cooling air restriction - in.H ₂ O - in.hg	0.5	0.037	0.5	0.037
Recommended "free area" intake louver size ft ² - m ²	8.85	0.82	8.95	0.83
a. Heat rejected to ambient, engine - Btu/min - kWm	1440	25	2000	35
b. Heat rejected to ambient, generator - Btu/min - kWm	356	6.25	356	6.25
Total heat rejection to ambient - Btu/min (a. + b.)	1796	31	2356	41.25

Exhaust system requirements

Exhaust gas flow - cfm - l/s	674	318	918	433
Exhaust temperature (dry manifold) - °F - °C	1098	592	1112	600
Maximum back pressure - in.hg - kPa (inclusive of silencer)	3	41	3	41
Exhaust outlet size - in. - mm	4	101.6	4	101.6
Emissions - NO _x - g/BHP-hr - g/kW-hr	Not Regulated		Meets EPA Tier One/CARB Consult factory for actual values	
Emissions - HC - g/BHP-hr - g/kW-hr				
Emissions - CO - g/BHP-hr - g/kW-hr				
Emissions - Particulates - PM - g/BHP-hr - g/kW-hr				

Fuel system requirements

Fuel consumption - 1/4 load - gph - Lph	1.9	7.3	2.7	10.2
Fuel consumption - 1/2 load - gph - Lph	3.5	13.1	4.8	18.3
Fuel consumption - 3/4 load - gph - Lph	4.7	17.8	7.3	27.5
Fuel consumption - full load - gph - Lph	7.0	26.5	9.4	35.7

Heat Exchanger Cooling system requirements

Minimum raw water (city water) flow - gpm - lps	Consult Baldor	Consult Baldor	Consult Baldor	Consult Baldor
Maximum supply water temperature - °F - °C	80°F	12.44°C	80°F	12.44°C

Remote Cooling system requirements

Maximum coolant static head - ft. - m	60	18.3	60	18.3
Ventilation required (based on 25°F temp rise) - cfm - lps	N/A	N/A	5236	92

Accessories and Options

Control Panel

- Louver Relay – 10 Amp
- Run Relay – 10 Amp
- Dry Contacts For Alarms
- Remote E-Stop
- Control Panel Heater
- Tachometer
- Remote Annunciator
- Remote Communication
- Panel Lights W/Switch
- Generator Voltage Adjust
- Modem For Remote Communication

Engine Exhaust System

- Industrial Silencer
- Residential Silencer
- Critical Silencer
- Exhaust Flex
- Exhaust Extension
- Rain Cap
- _____

Generator Accessories

- Main Line Circuit Breaker
- Exciter Field Circuit Breaker
- Ground Fault Module W/Breaker Shunt Trip
- Ground Fault Module W/O Breaker Shunt Trip
- Reconnectable Link Bars
- Drip Cover IP22
- Manual Voltage Control
- Space Heater
- RTD's Stator Windings
- RTD's Bearing (Rear)
- PMG
- MVC300 Manual Voltage Control

Engine Electrical System

- Batteries
- Battery Rack
- Battery Cables
- Battery Charger - Automatic
- Battery Charger - Trickle
- _____

Engine Fuel System

- Weather Proof Enclosure
- Sound Attenuated Enclosure
- Trailer Mounted
- Vibration Isolators
- Coolant Heater
- Bypass Oil Filter
- Export Crating
- _____
- _____
- _____
- _____

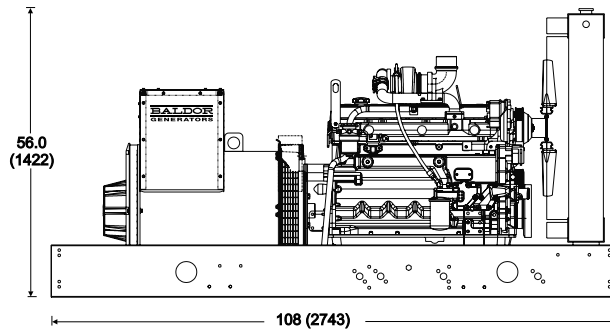
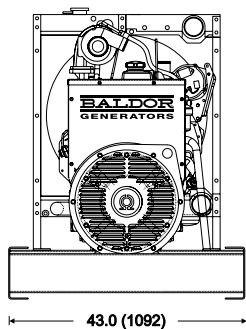

Dimensions – in (mm)

Weight – lbs. (Kg)
2652 (1204)

Cubes (Approximate)
150.5 ft

*Open unit configuration,
accessories not included

Distributed by:



3815 Oregon Street • Oshkosh, WI 54902 • 1-800-872-7697 • Phone (920) 236-4200 • Fax (920) 236-4219
909 Perkins Drive • Mukwonago, WI 53149 • Phone (262) 363-1555 • Fax (262) 363-1556

World Headquarters

Baldor Electric Company • P.O. Box 2400 • Fort Smith, AR 72902-2400 U.S.A.
Phone (479) 646-4711 • Fax (479) 648-5792 • International Fax (479) 648-5895

www.baldor.com