

Standby or Prime Power Features

- Heavy-duty diesel engine
- Solid state CMOS controls feature full adjustability for maximum flexibility
- PMG Excitation System to provide 300% rated current for a minimum of ten seconds to selectively trip breakers (std on 800 kW and up)
- Prototype tested per NFPA 110
- Aluminum die cast rotor core providing high mechanical integrity and low vibration at operating speed (std on 800 kW and up)
- Heavy-duty construction for use in prime or standby application

Gen Set Ratings

Baldor Genset Model	kW Rating Standby	kW Rating Prime	Voltage Hi-Wye	Voltage Low-Wye	Voltage Delta	Number of Leads	Phase	Hz	Power Factor
IDLC275-DA	275	260	480/277	240/139	N/A	12	3	60	0.8
IDLC275-DA	275	260	440/254	220/127	N/A	12	3	60	0.8
IDLC275-DA	275	260	416/240	208/120	240/120	12	3	60	0.8
IDLC275-DB	275	260	380/190	N/A	N/A	12	3	60	0.8
IDLC275-DH	275	260	600/347	N/A	N/A	12	3	60	0.8
IDLC275-DXB	240	225	380/220	N/A	N/A	12	3	50	0.8

NOTES: For ratings and voltages not listed above refer to the Gen-Set Selector or consult factory
 Standby ratings do not have an overload capability but can be used for the duration of the utility failure per ISO-3046, DIN6271 and BS5514
 Prime (Unlimited Running Time) ratings are continuous per DIN 6271 and ISO-3046 with 10% overload capacity
 Base Load (Continuous) ratings are continuous per DIN 6271, BS5514 and ISO-8528 with no sustained overload capacity
 Consult factory for Base Load ratings
 Altitude derate is 4% for each 1000 feet over 2500 @ 1800 RPM, 5000 @ 1500 RPM
 Temperature derate is 1% for 10°F over 104°F ambient
 Fuel consumption will vary, values are estimates

Controls Digital Control Module

MEC2 Features

- Large Backlit LCD with alpha-numeric readout
- Microprocessor Based Design
- 16 programmable alarms/shutdowns set points
- 4 programmable inputs
- Alarm horn
- Not in Automatic Alarm
- Digital Three Phase Voltage and Current Monitoring
- Password Protected Front Panel Programming
- 4 Programmable Outputs
- Local Emergency Stop Switch
- Optional NFPA110 Level I

Engine Protections

- Digital Oil Pressure Gauge
- Digital Water Temperature Gauge
- Digital Battery Voltmeter
- Overspeed Shutdown
- Emergency Stop Shutdown
- Loss of Speed Signal
- Overcrank Shutdown

Designed To Meet/Exceed the Standards Below:

- UL 508
- UL 2200
- NFPA 70
- NFPA 110

Engine Technical Data

Manufacturer	Detroit
Engine Model	Series 60 (12.7L) - 6063TK35
Engine Type	4 cycle, 6 cylinders
Engine Horsepower	490
Aspiration	Turbocharged
No. of Cylinders & Configuration	In-line
Displacement - cu. in. (liters)	778 (12.7)
Bore and Stroke - in. (mm)	5.12 x 6.30 (130 x 160)
Compression Ratio	15.0:1
Air Filter Type	Dry
Governor Type	Electronic
Governor Make	DDC
Governor Model	DDEC
Frequency Regulation, steady state	.25%
Frequency Regulation, no load to full load	Isochronous
Battery Voltage	24 VDC
Water Pump Type	Centrifugal
Coolant Cap. - radiator cooled - qts (liters)	30 (28)
Coolant Capacity - engine only - gals (liters)	6 (22.71)
Oil Pan Capacity - gals (liters)	6.5-8 (25-30)
Rec'd Oil Type - SF/CC/CD-10°F to 90°F	15W-40

Engine Operational Values	English 50 Hz	Metric 50 Hz	English 60 Hz	Metric 60 Hz
Maximum ambient temperature - F° - C°	104/122	40/50	104/122	40/50
Heat rejected to coolant - Btu/min - kWm	6450	113	7750	136
Max. power at rated rpm - bhp - kWm	390	291	490	366
Coolant flow - gpm - l/s at 2 PSI	80	5	96	6.1
Exhaust temperature - F° - C°	801	427	780	416
Exhaust flow - cfm - m ³ /min	2019	953	2562	1209
Normal oil press. range idle/run - PSI - kgf/cm ²	12/50	83/345	12/50	83/345
Max fuel flow to injection pump - gph - Lph	75	284	66	250

Gen Set Technical Data

Alternator Technical Data

Generator Frame	4	Voltage Regulation NL - FL	+/- 1.0%
Exciter	Brushless	Underspeed Protection	Standard
Cooling Fan	Cast alloy aluminum	Overexcitation Protection	Standard
Bearing	Single, double shielded	Overvoltage Protection	Standard
Connection Type	Reconnectable	Loss of Sensing Protection	Standard
Insulation Type	Class H	Overspeed	2250 RPM
Windings	100% copper	Standards	NEMA, IEC, IEEE, CSA, BS
Pitch	2/3	Phase Sequence	A(U),B(V),C(W)
Amortisseur Winding	Full	TIF (1960 Weightings)	<50
Voltage Regulator	SX440	Excitation System	PMG - Optional

Alternator Performance Data	Model IDLC275-DA	Model IDLC275-DB	Model IDLC275-DH
Temperature rise by resistance - °C (Stand-By)	150/40	150/40	150/40
Generator model number	HCI444D	HCI444E	HCI444D
Generator kW at 130/105/80°C over 40°C ambient (480 Volt , 60Hz)	300/272/236	335/305/268	300/272/236
SKVA output with 30% voltage dip max. 100% recovery at 60 Hz	730	850	730
Maximum skva at 90% sustained voltage dip	Consult Factory	Consult Factory	Consult Factory
Subtransient reactance at voltage listed	13.00%	12.00%	13.00%
Line - line harmonic maximum total	5.00%	5.00%	5.00%

Installation/Application Data	English 50 Hz	Metric 50 Hz	English 60 Hz	Metric 60 Hz
Ventilation requirements				
a. Cooling airflow required - cfm - m ³ /min (unit mounted radiator)	19923	9404	23908	11285
b. Combustion air required - cfm - m ³ /min	875	413	1070	505
Total ventilation requirements - cfm - m³/min (a. + b.)	20798	9817	24978	11790
Maximum cooling air restriction - in.H ₂ O - in.hg	0.5	0.037	0.5	0.037
Recommended minimum intake louver size (based on "free area")	21	2	25	2
a. Heat rejected to ambient, engine - Btu/min - kWm	6450	113	7750	136
b. Heat rejected to ambient, generator - Btu/min - kWm	783	14	783	14
Total heat rejection to ambient - Btu/min (a. + b.)	7233	127	8533	150
Exhaust system requirements				
Exhaust gas flow - cfm - m ³ /min	2019	953	2562	1209
Exhaust temperature (dry manifold) - °F - °C	801	427	780	416
Maximum back pressure - in.H ₂ O - mm H ₂ O (inclusive of silencer)	2.1	701	3	10.2
Exhaust outlet size - in. - mm	5	127	5	127
Emissions - NO _x - g/BHP-hr - g/kW-hr	Consult Factory for Actual Values		6.56	4.89
Emissions - HC - g/BHP-hr - g/kW-hr			0.07	0.05
Emissions - CO - g/BHP-hr - g/kW-hr			0.39	0.29
Emissions - PM - g/BHP-hr - g/kW-hr			0.36	0.27
Fuel system requirements				
Fuel consumption - 1/4 load - gph - Lph	5	19	6	23
Fuel consumption - 1/2 load - gph - Lph	9	34	11	43
Fuel consumption - 3/4 load - gph - Lph	13	50	17	63
Fuel consumption - Full load - gph - Lph	17	65	22	84
Heat Exchanger Cooling system requirements				
Minimum raw water (city water) flow - gpm - lps	Consult Factory			
Maximum supply water temperature - °F - °C				
Remote Cooling system requirements				
Maximum coolant static head - ft. - m	Consult Factory			
Ventilation required (based on 25°F temp rise) - cfm - lps				

Accessories and Options

Control Panel

- Louver Relay – 10 Amp
- Run Relay – 10 Amp
- Dry Contacts For Alarms
- Remote E-Stop
- Control Panel Heater
- Tachometer
- Remote Annunciator
- Remote Communication
- Panel Lights w/Switch
- Generator Voltage Adjust
- Modem For Remote Communication

Engine Exhaust System

- Industrial Silencer
- Residential Silencer
- Critical Silencer
- Exhaust Flex
- Exhaust Extension
- Rain Cap
- _____

Generator Accessories

- Main Line Circuit Breaker
- Exciter Field Circuit Breaker
- Ground Fault Module w/Breaker Shunt Trip
- Ground Fault Module w/o Breaker Shunt Trip
- Reconnectable Link Bars
- Drip Cover IP22
- Manual Voltage Control
- Space Heater
- RTD's Stator Windings
- RTD's Bearing (Rear)
- PMG
- MVC300 Manual Voltage Control

Engine Electrical System

- Batteries
- Battery Rack
- Battery Cables
- Battery Charger - Automatic
- Battery Charger - Trickle
- _____

Engine Fuel System

- Day Tank
- Sub-Base Fuel Tank
- Storage Tank
- Flexible Fuel Lines
- _____

Miscellaneous

- Weather Proof Enclosure
- Sound Attenuated Enclosure
- Trailer Mounted
- Vibration Isolators
- Coolant Heater
- Oil Heater
- Bypass Oil Filter
- Export Crating

- _____
- _____
- _____
- _____

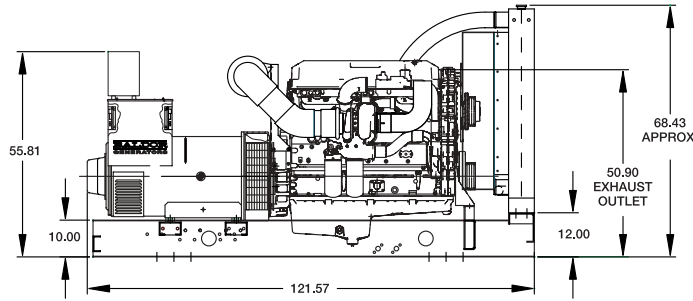
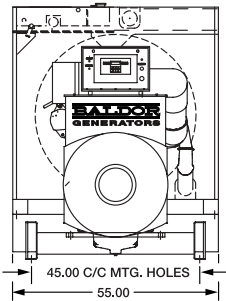

Dimensions – in (mm)

Weight – lbs. (Kg)
6546 (2969)

Cubes (Approximate)
270 ft

*Open unit configuration,
accessories not included

Distributed by:



3815 Oregon Street • Oshkosh, WI 54902 • 1-800-872-7697 • Phone (920) 236-4200 • Fax (920) 236-4219
909 Perkins Drive • Mukwonago, WI 53149 • Phone (262) 363-1555 • Fax (262) 363-1556

World Headquarters

Baldor Electric Company • P.O. Box 2400 • Fort Smith, AR 72902-2400 U.S.A.
Phone (479) 646-4711 • Fax (479) 648-5792 • International Fax (479) 648-5895

www.baldor.com