

Standby or Prime Power Features

- Heavy-duty industrial diesel engine
- Brushless synchronous alternators: four-pole construction, dynamically balanced
- Full featured microprocessor based controller: fully programmable for maximum flexibility
- Prototype tested and production tested
- Gen-set accepts rated load in one step
- UL2200 available – consult factory
- Optional weather-proof and sound attenuated enclosures available
- Full range of accessories and options available
- Heavy-duty construction for use in prime or standby application
- Manufactured in an ISO-9001 certified facility
- Backed by a world wide network of parts and service center

Gen Set Ratings

Baldor Genset Model	kW Rating Standby	kW Rating Prime	Voltage Hi-Wye	Voltage Low-Wye	Voltage Delta	Number of Leads	Phase	Hz	Power Factor
IDLC900-MA	900	825	480/277	240/139	N/A	12	3	60	0.8
IDLC900-MA	900	825	440/254	220/127	N/A	12	3	60	0.8
IDLC900-MB	900	825	416/240	208/120	240/120	12	3	60	0.8
IDLC900-MC	900	825	380/220	N/A	N/A	12	3	60	0.8
IDLC900-MH	900	825	600/347	N/A	N/A	12	3	60	0.8
N/A			380/220	N/A	N/A	12	3	50	0.8

NOTES: For ratings and voltages not listed above refer to the Gen-Set Selector or consult factory
 Standby ratings do not have an overload capability but can be used for the duration of the utility failure per ISO-3046, DIN6271 and BS5514
 Prime (Unlimited Running Time) ratings are continuous per DIN 6271 and ISO-3046 with 10% overload capacity
 Base Load (Continuous) ratings are continuous per DIN 6271, BS5514 and ISO-8528 with no sustained overload capacity
 Consult factory for Base Load ratings
 Altitude derate is 4% for each 1000 feet over 5000
 Temperature derate is 1% for 10°F over 100°F ambient

Controls Digital Control Module

MEC2 Features

- Large Backlit LCD with alpha-numeric readout
- Microprocessor Based Design
- 16 programmable alarms/shutdowns set points
- 4 programmable inputs
- Alarm horn
- Not in Automatic Alarm
- Digital Three Phase Voltage and Current Monitoring
- Password Protected Front Panel Programming
- 4 Programmable Outputs
- Local Emergency Stop Switch
- Optional NFPA110 Level I

Engine Protections

- Digital Oil Pressure Gauge
- Digital Water Temperature Gauge
- Digital Battery Voltmeter
- Overspeed Shutdown
- Emergency Stop Shutdown
- Loss of Speed Signal
- Overcrank Shutdown

Designed To Meet/Exceed the Standards Below:

- UL 508
- UL 2200
- NFPA 70
- NFPA 110

Engine Technical Data

Hertz	60 Hz
Manufacturer	Mitsubishi
Engine Model	S12H-Y1PTA-3
Engine Type	4 cycle, Water cooled
Aspiration	Turbocharged and Aftercooled
No. of Cylinders & Configuration	V-12, 60°V
Displacement - cu. in. (liters)	2265 (37.11)
Bore and Stroke - in. (mm)	5.91 X 6.89 (150 X 175)
Compression Ratio	14.5:1
Air Filter Type	Dry
Governor Type	Electronic
Governor Make	Woodward
Governor Model	Woodward Pro-Act II
Frequency Regulation, steady state	+/- 0.25%
Frequency Regulation, no load to full load	Isochronous
Battery Voltage	24 VDC
Water Pump Type	Centrifugal
Coolant Cap. - radiator cooled - qts - liters	184 / 174
Coolant Capacity - engine only - gals - liters	26.4 (100)
Oil Pan Capacity - gals - liters	39.6-47.6/150-180
Rec'd Oil Type - SF/CC/CD-10°F to 90°F	10W-40

Engine Operational Values	English 60 Hz	Metric 60 Hz
Maximum ambient temperature - F° - C°	104/122	40/50
Heat rejected to coolant - Btu/min - kWm	41,752	734
Max. power at rated rpm - bhp - kWm	1,528	1,140
Coolant flow - gpm - lpm	383	1,450
Exhaust temperature - F° - C°	1,015	546
Exhaust flow - cfm - m ³ /min	9,392	266
Normal oil press. range idle/run - PSI - kgf/cm ²	29-43/71-86	2-3/5-6
Max fuel flow to injection pump - gph - Lph	462	1750

Gen Set Technical Data

Alternator Technical Data

Generator Frame	6	Voltage Regulation NL - FL	+/- 0.5%
Exciter	Brushless	Underspeed Protection	Standard
Cooling Fan	Cast alloy aluminum	Overexcitation Protection	Standard
Bearing	Single, double shielded	Overvoltage Protection	Standard
Connection Type	Reconnectable / 6 Lead	Loss of Sensing Protection	Standard
Insulation Type	Class H	Overspeed	2250 RPM
Windings	100% copper	Standards	NEMA, IEC, IEEE, CSA, BS
Pitch	2/3	Phase Sequence	A(U), B(V), C(W)
Amortisseur Winding	Full	TIF (1960 Weightings)	<50
Voltage Regulator	MX321	Excitation System	PMG - Standard

Alternator Performance Data

	Model IDLC900-MA	Model IDLC900-MB	Model IDLC900-MC	Model IDLC900-MH
Temperature rise by resistance - °C (Stand-By)	150/40	150/40	150/40	150/40
Generator model number	HCI634H	HCI634J	HCI634K	HCI634H
Generator kW at 125/105/80°C over 40°C ambient (480 Volt , 60Hz)	900/820/720	1040/950/828	1150/1050/900	900/820/720
SkVA output with 30% voltage dip max. 100% recovery at 60 Hz	2700	3000	3800	2700
Maximum SkVA at 90% sustained voltage dip	Consult Baldor	Consult Baldor	Consult Baldor	Consult Baldor
Subtransient reactance at voltage listed	16%	16.00%	15.00%	16.00%
Line - line harmonic maximum total	5.00%	5.00%	5.00%	5.00%

Installation/Application Data

	English 60 Hz	Metric 60 Hz
Ventilation requirements		
a. Cooling airflow required - cfm - m ³ /min (unit mounted radiator)	63,558	1,800
b. Combustion air required - cfm - m ³ /min	3,566	101
Total ventilation requirements - cfm - m³/min (a. + b.)	67,124	1,901
Maximum cooling air restriction - in.H ₂ O - in.hg	0.500	0.037
Recommended minimum intake louver size (based on "free area")	67	2
a. Heat rejected to ambient, engine - Btu/min - kWm	5,010	88
b. Heat rejected to ambient, generator - Btu/min - kWm	2,561	45
Total heat rejection to ambient - Btu/min (a. + b.)	7,571	133
Exhaust system requirements		
Exhaust gas flow - cfm - m ³ /min	9,392	266
Exhaust temperature (dry manifold) - °F - °C	1,015	546
Maximum back pressure - in.H ₂ O - mm H ₂ O (inclusive of silencer)	24	600
Exhaust outlet size - in. - mm	10	254
Emissions - NO _x - g/BHP-hr - g/kW-hr	5.82	7.80
Emissions - HC - g/BHP-hr - g/kW-hr	0.37	0.50
Emissions - CO - g/BHP-hr - g/kW-hr	0.52	0.70
Emissions - PM - g/BHP-hr - g/kW-hr	0.11	0.15
Fuel system requirements		
Fuel consumption - 1/4 load - gph - Lph	23	284
Fuel consumption - 1/2 load - gph - Lph	39	212
Fuel consumption - 3/4 load - gph - Lph	56	148
Fuel consumption - Full load - gph - Lph	75	87
Heat Exchanger Cooling system requirements		
Minimum raw water (city water) flow - gpm - lps	Consult Baldor	Consult Baldor
Maximum supply water temperature - °F - °C		
Remote Cooling system requirements		
Maximum coolant static head - ft. - m	Consult Baldor	Consult Baldor
Ventilation required (based on 25°F temp rise) - cfm - lps		

Accessories and Options

Control Panel

- Louver Relay – 10 Amp
- Run Relay – 10 Amp
- Dry Contacts For Alarms
- Remote E-Stop
- Control Panel Heater
- Tachometer
- Remote Annunciator
- Remote Communication
- Panel Lights w/Switch
- Generator Voltage Adjust
- Modem For Remote Communication

Engine Exhaust System

- Industrial Silencer
- Residential Silencer
- Critical Silencer
- Exhaust Flex
- Exhaust Extension
- Rain Cap
- _____

Generator Accessories

- Main Line Circuit Breaker
- Exciter Field Circuit Breaker
- Ground Fault Module w/Breaker Shunt Trip
- Ground Fault Module w/o Breaker Shunt Trip
- Reconnectable Link Bars
- Drip Cover IP22
- Manual Voltage Control
- Space Heater
- RTD's Stator Windings
- RTD's Bearing (Rear)
- PMG
- MVC300 Manual Voltage Control

Engine Electrical System

- Batteries
- Battery Rack
- Battery Cables
- Battery Charger - Automatic
- Battery Charger - Trickle
- _____

Engine Fuel System

- Day Tank
- Sub-Base Fuel Tank
- Storage Tank
- Flexible Fuel Lines
- _____

Miscellaneous

- Weather Proof Enclosure
- Sound Attenuated Enclosure
- Trailer Mounted
- Vibration Isolators
- Coolant Heater
- Oil Heater
- Bypass Oil Filter
- Export Crating

- _____
- _____
- _____
- _____

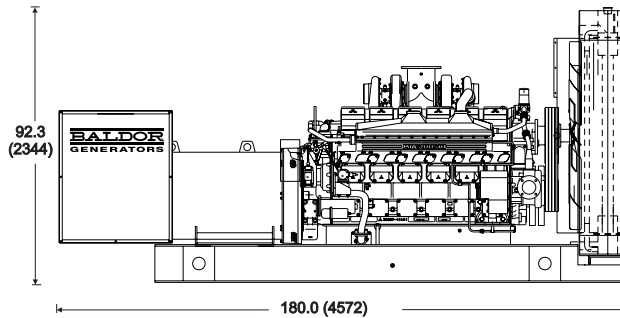
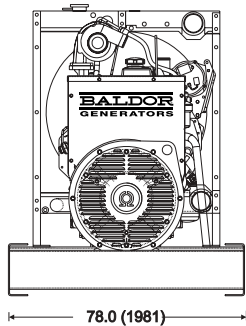

Dimensions – in (mm)

Weight – lbs. (Kg)
17,295 (7828)

Cubes (Approximate)
700 ft

*Open unit configuration,
accessories not included

Distributed by:

BALDOR GENERATORS

3815 Oregon Street • Oshkosh, WI 54902 • 1-800-872-7697 • Phone (920) 236-4200 • Fax (920) 236-4219
909 Perkins Drive • Mukwonago, WI 53149 • Phone (262) 363-1555 • Fax (262) 363-1556

World Headquarters

Baldor Electric Company • P.O. Box 2400 • Fort Smith, AR 72902-2400 U.S.A.
Phone (479) 646-4711 • Fax (479) 648-5792 • International Fax (479) 648-5895

www.baldor.com