

PLAN VIEW

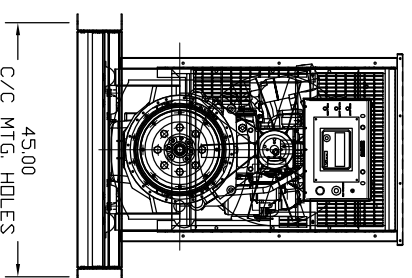

REAR VIEW

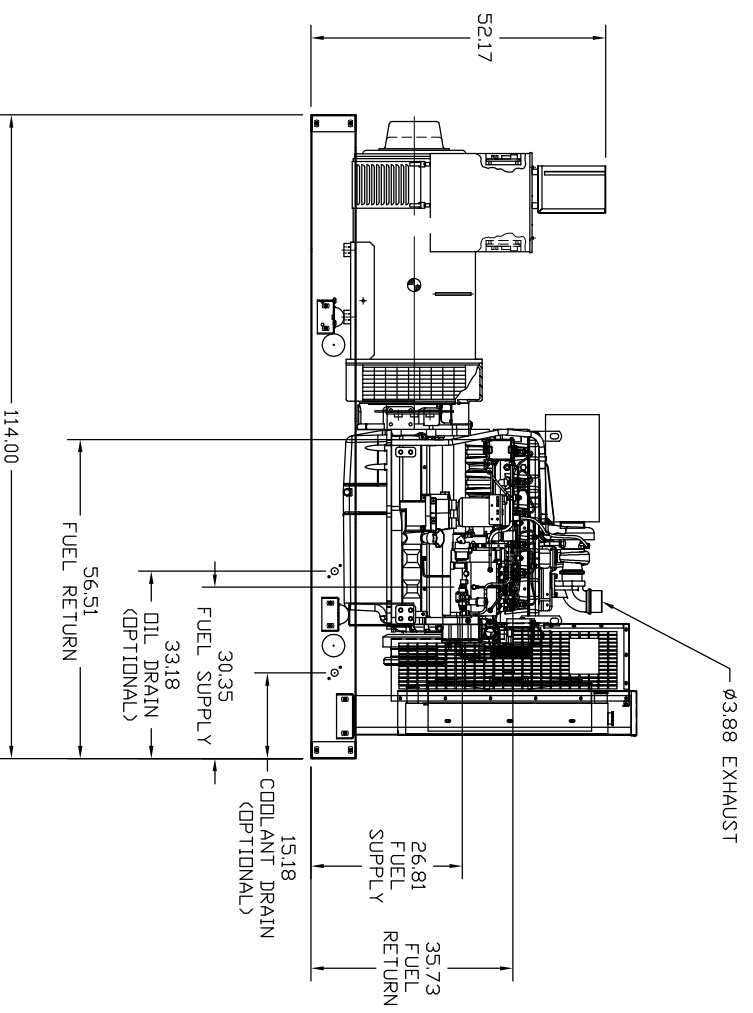

RIGHT VIEW

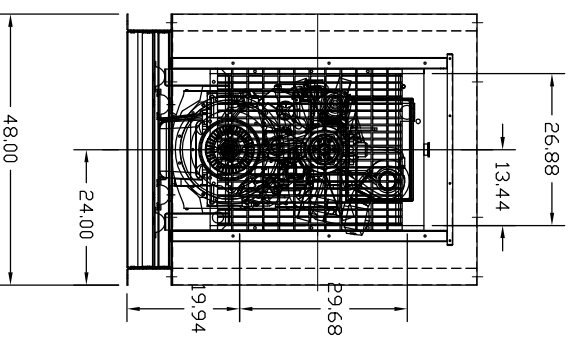

FRONT VIEW

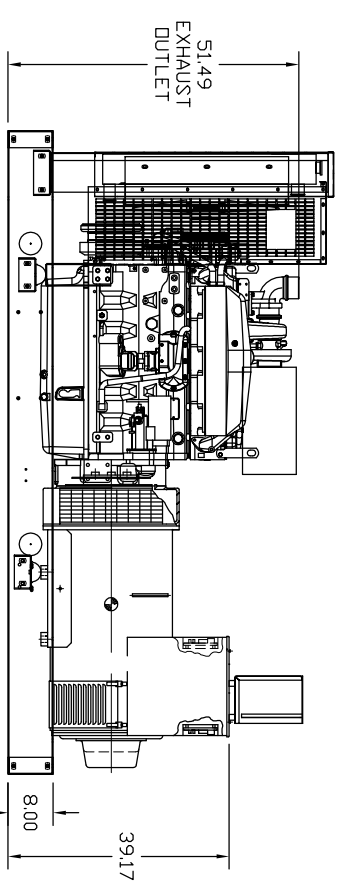

LEFT VIEW

JOHN DEERE		WET WEIGHT		5500 Lbs.		
TANK RUN TIME	TANK CAPACITY	TANK PART #	LENGTH	WIDTH	HEIGHT	ADDITIONAL WEIGHT (EMPTY)
12 Hours	210 GAL	TA0000B54	114"	48"	18"	1300 LBS
24 Hours	420 GAL	TA0000B68	114"	48"	38"	1800 LBS

REV. DESC: NEW	VERSION: 00	TDR: 000000339114
REV. LTR: -	REVISED: 11:03:45 11/29/2004	BY: PGJOEEO
FILE: \PGA\00006\246		
MTL: -		

**BALDOR ELECTRIC Co.**

IDLC230,JD,OPEN,STD