

AY0080C05

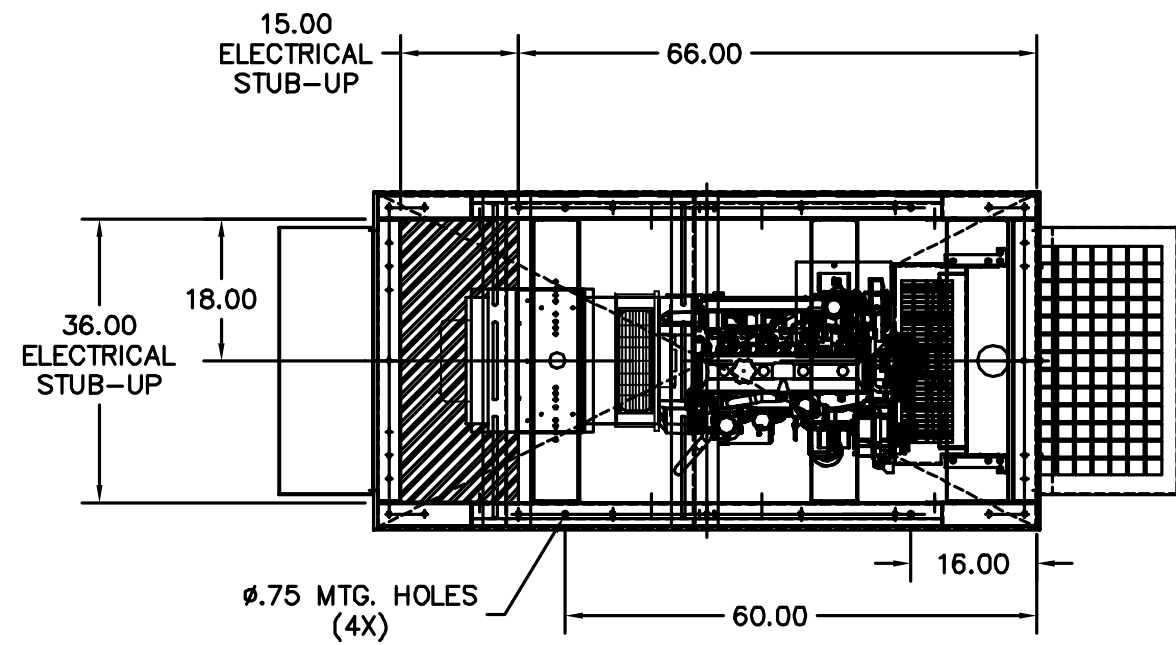

PLAN VIEW

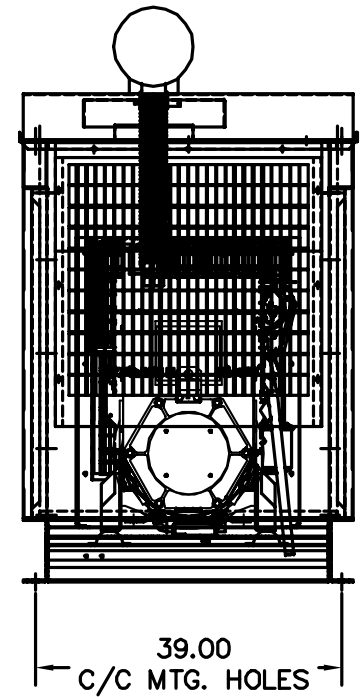

REAR VIEW

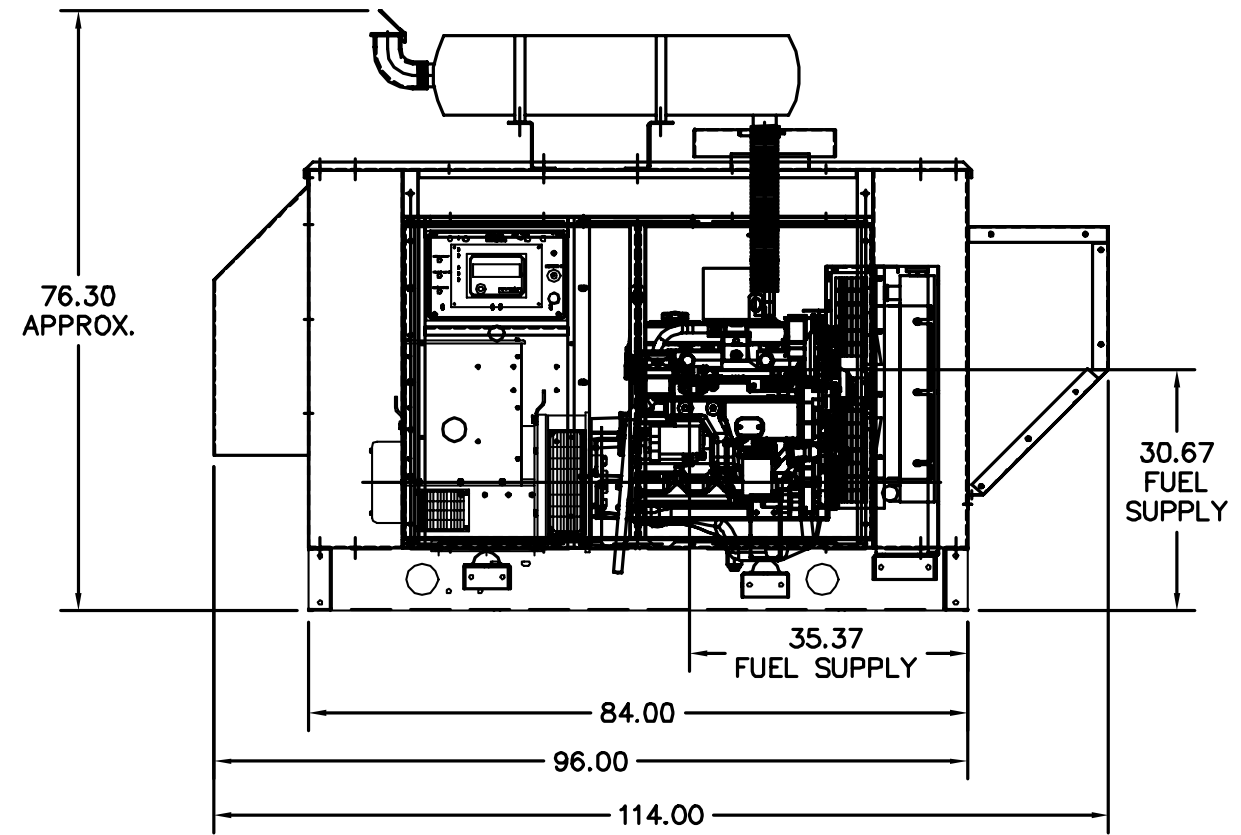

RIGHT VIEW

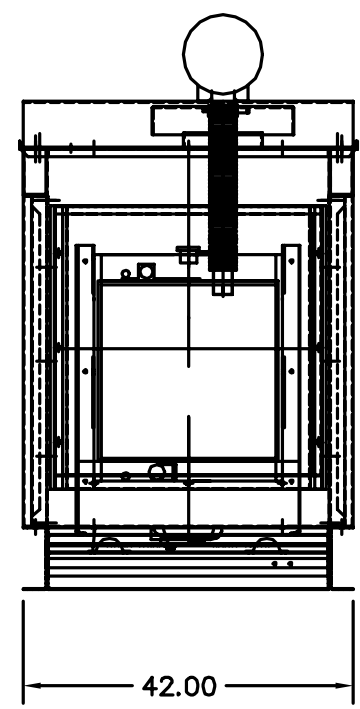

FRONT VIEW

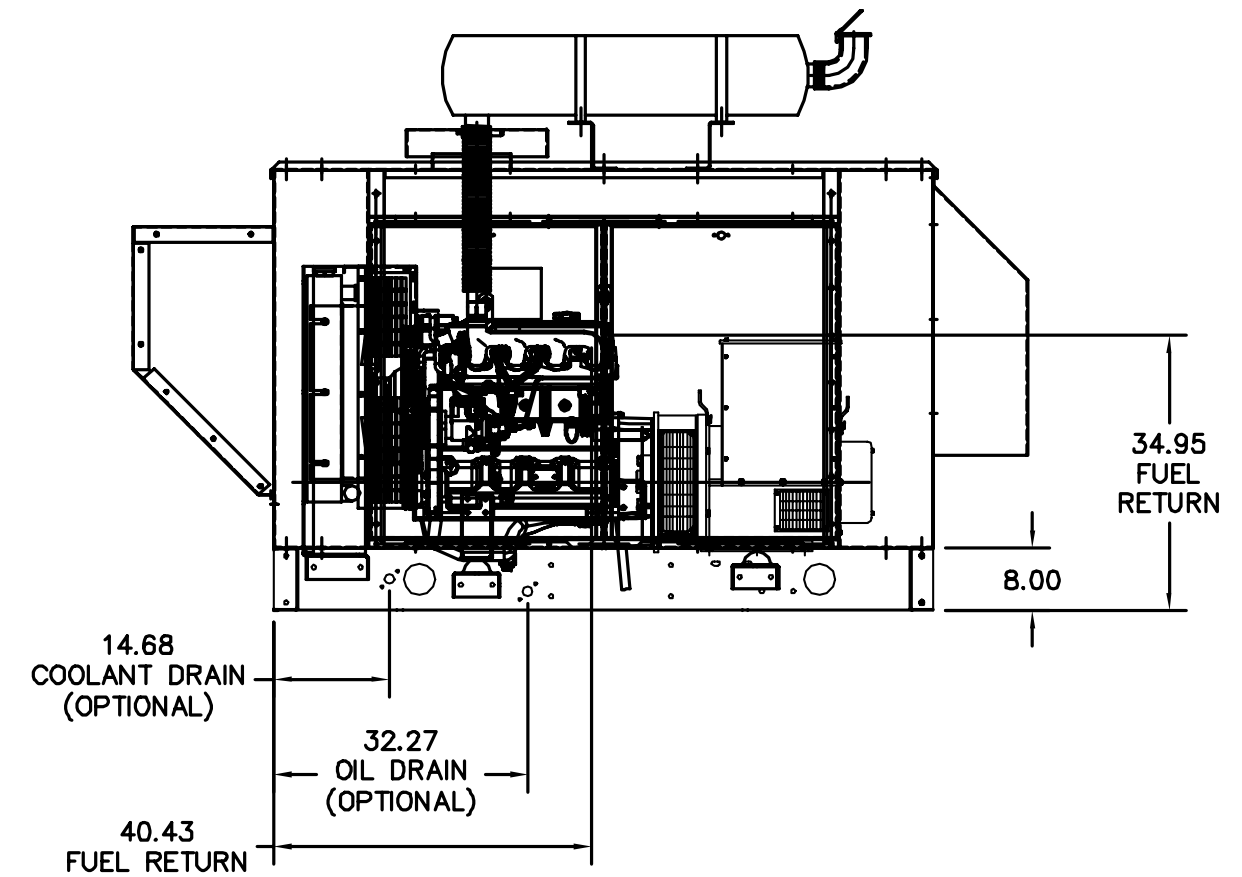

LEFT VIEW

JOHN DEERE			WET WEIGHT			3060 Lbs.
TANK RUN TIME	TANK CAPACITY	TANK PART #	LENGTH	WIDTH	HEIGHT	ADDITIONAL WEIGHT (EMPTY)
12 Hours	50 GAL	TA0000B36	84"	42"	10"	600 LBS
24 Hours	90 GAL	TA0000B51	84"	42"	15"	900 LBS

REV. DESC: NEW	VERSION: 00	TDR: 000000339114
REV. LTR: -	REVISED: 08:09:26 11/23/2004	BY: PGJOEE0
FILE: \PGA\00005\857		
MTL: -		

BALDOR ELECTRIC Co.

IDLC30,JD,ECON W/ FOAM,STD

AY0080C05