

AY0080C16

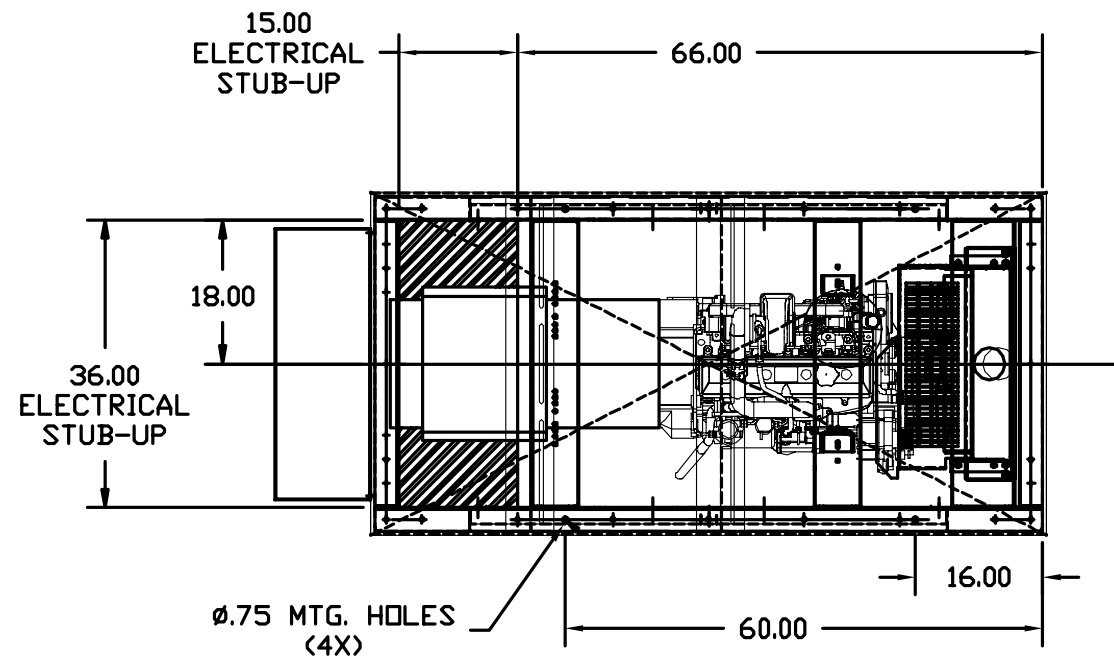

PLAN VIEW

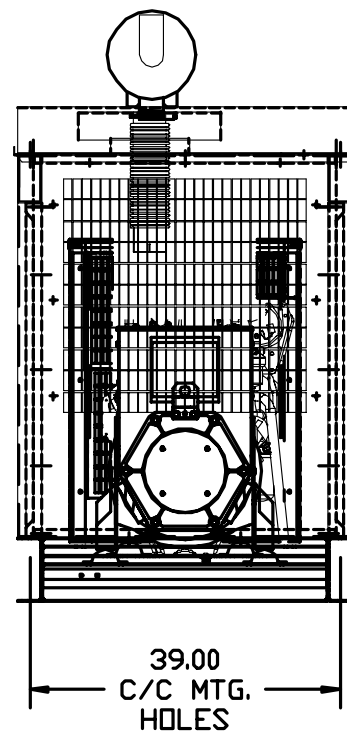

REAR VIEW

JOHN DEERE		WET WEIGHT			3000 Lbs.	
TANK RUN TIME	TANK CAPACITY	TANK PART #	LENGTH	WIDTH	HEIGHT	ADDITIONAL WEIGHT (EMPTY)
12 Hours	70 GAL	TA0000B37	84"	42"	12"	700 LBS
24 Hours	125 GAL	TA0000B35	84"	42"	18"	900 LBS

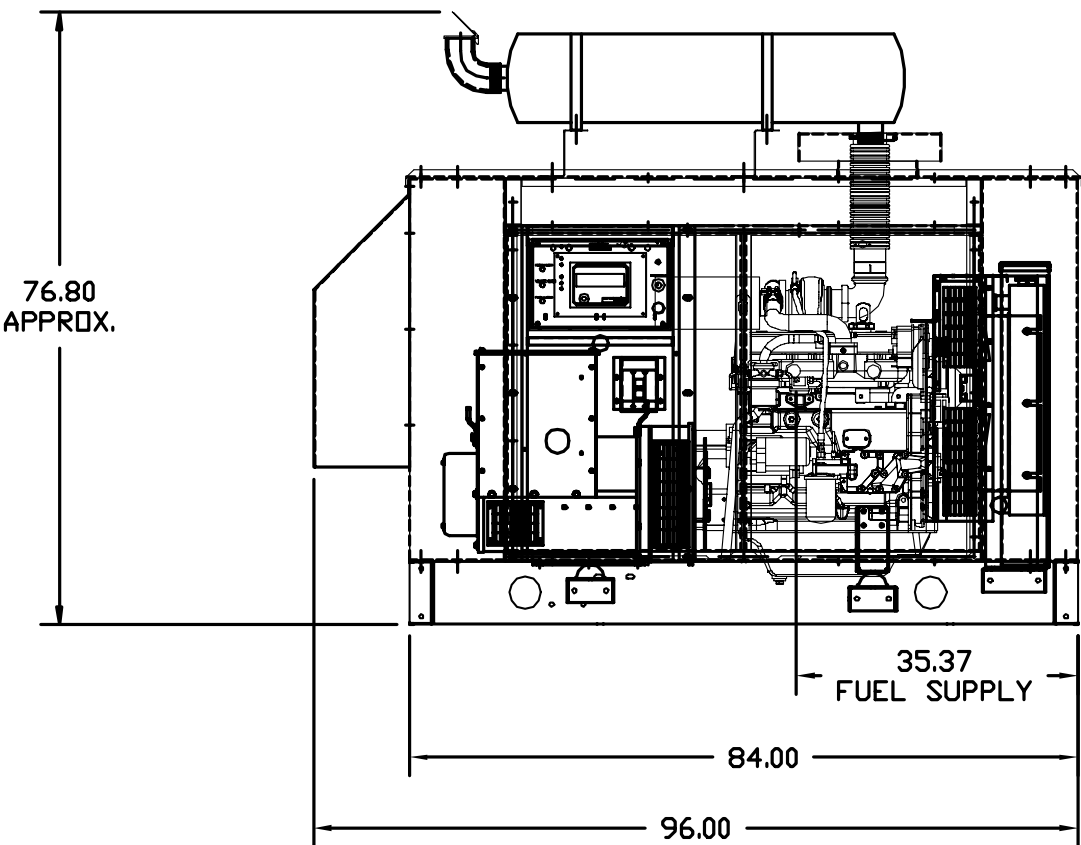

RIGHT VIEW

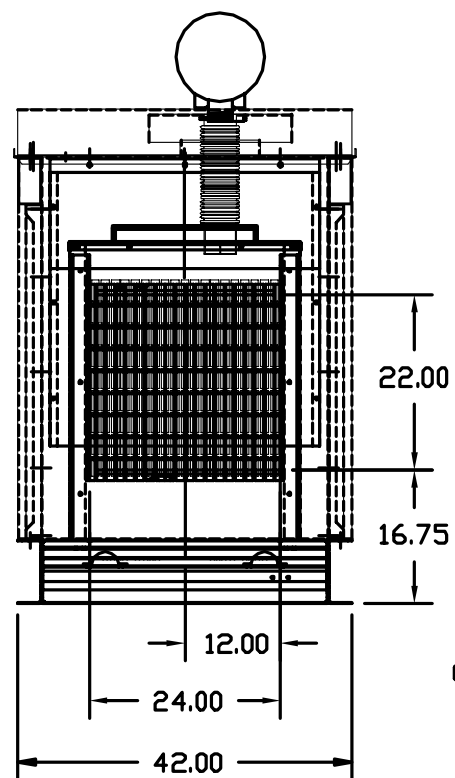

FRONT VIEW

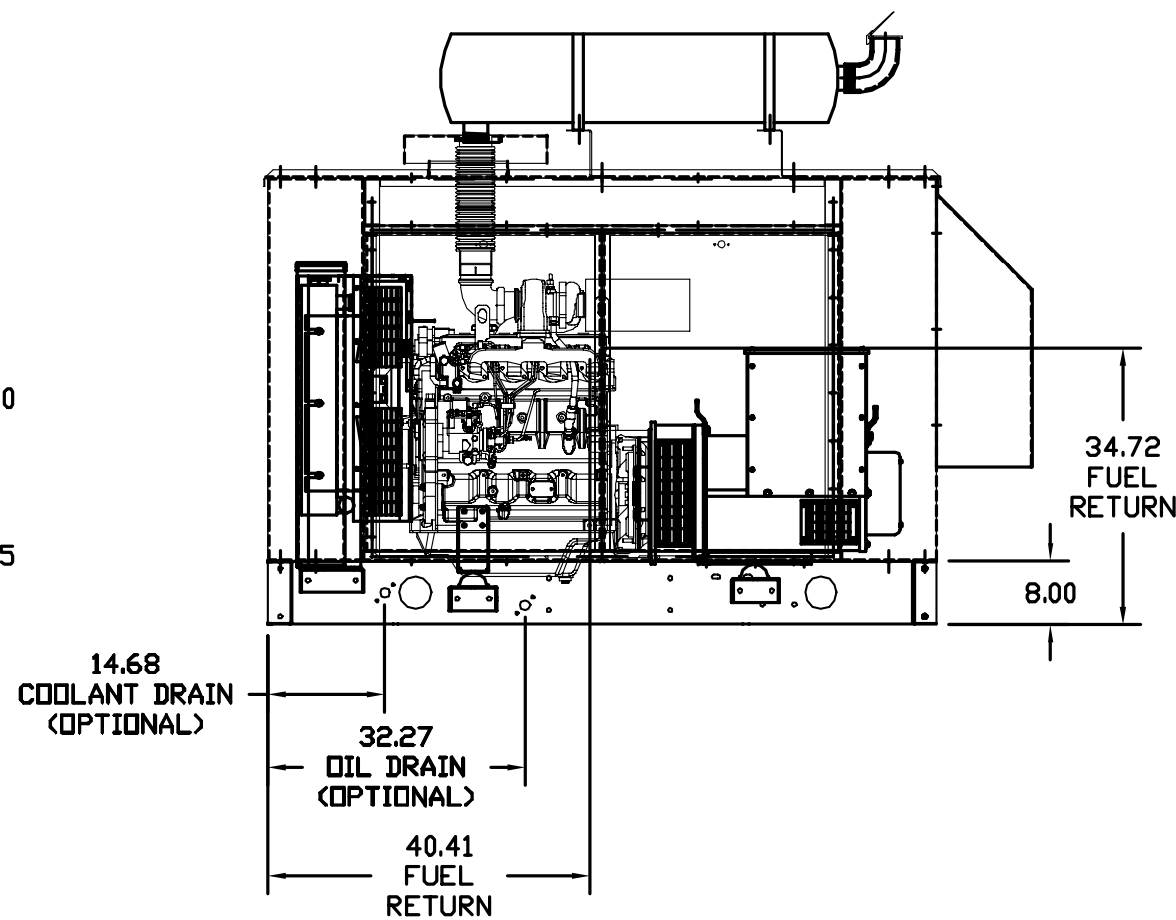

LEFT VIEW

REV. DESC: NEW	VERSION: 00	TDR: 000000339114
REV. LTR: -	REVISED: 13: 21: 01 11/23/2004	BY: PGRICLO
FILE: \PGA\00005\871		
MTL: -		

**BALDOR ELECTRIC Co.**

IDLC50,JD,ECON,STD

AY0080C16