

PLAN VIEW

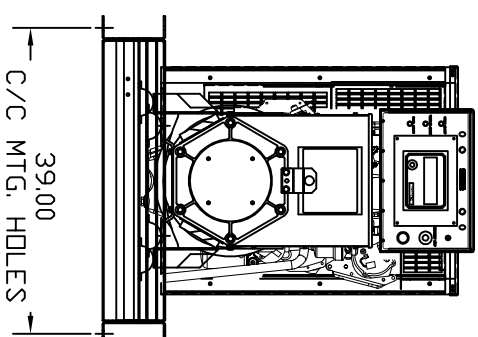

REAR VIEW

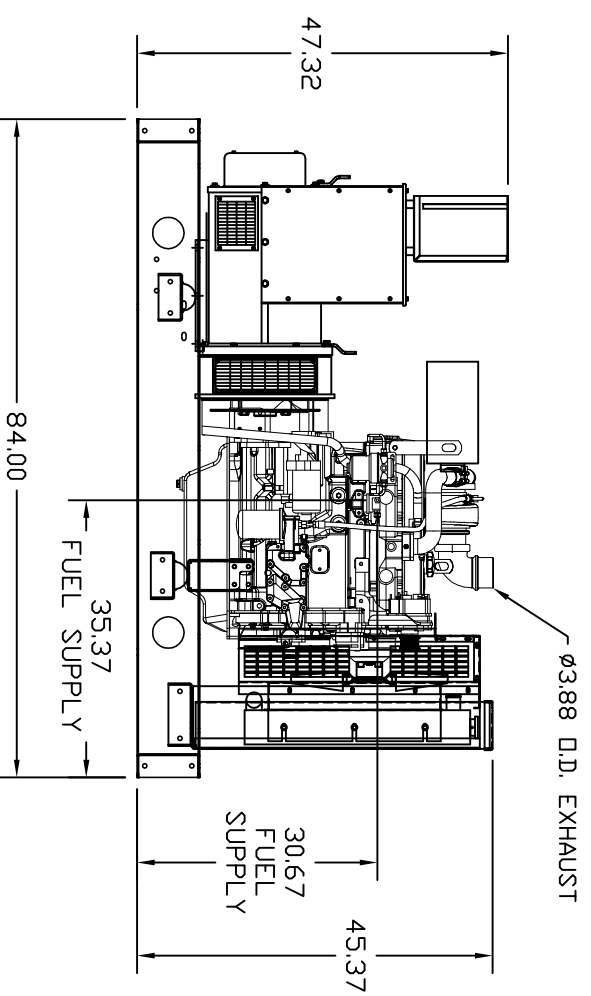

RIGHT VIEW

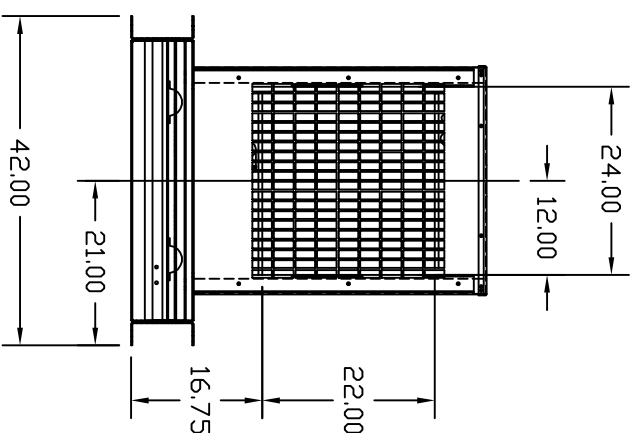

FRONT VIEW

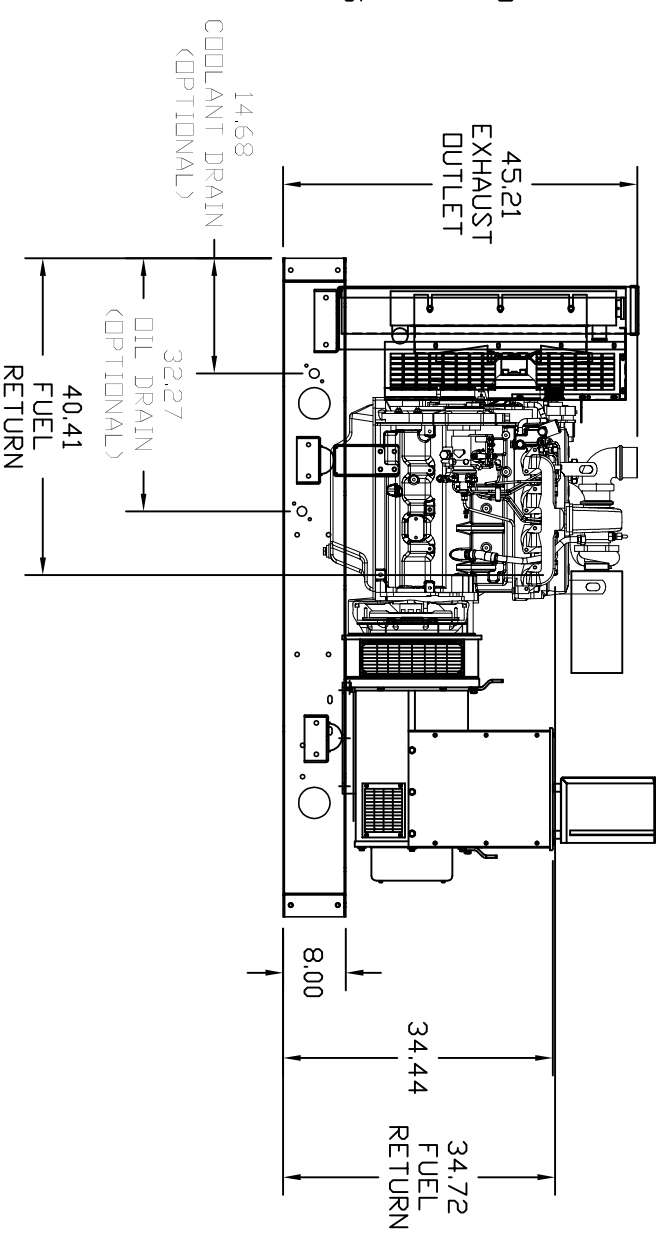

LEFT VIEW

JOHN DEERE		WET WEIGHT		2200 Lbs.		
TANK RUN TIME	TANK CAPACITY	TANK PART #	LENGTH	WIDTH	HEIGHT	ADDITIONAL WEIGHT (EMPTY)
12 Hours	70 GAL	TA0000B37	84"	42"	12"	700 LBS
24 Hours	125 GAL	TA0000B35	84"	42"	18"	900 LBS

REV. DESC: NEW	VERSION: 00	TDR: 000000339114
REV. LTR: -	REVISED: 13:45:55 11/23/2004	BY: PGRICLO
FILE: \PGA\00005\878		
MTL: -		

BALDOR ELECTRIC Co.

IDLC60,JD,OPEN,STD